

## Description



The DELZONE® MPI-300 is a self-contained ozone sanitation system that provides ozone-enriched cold water on demand for hard surface sanitation and direct food contact applications. Available “plug and play” in either wall-mount or mobile cart configurations, the MPI-300 provides 3.3 GPM water flow with a residual ozone dose of approximately 2.0 PPM at the nozzle, with a 25’ foot ozone delivery hose and spray wand.

## Benefits of Ozone Sanitation

- FDA, USDA, and EPA approved antimicrobial agent
- USDA National Organic Program allowed ingredient
- Hard surface sanitation and direct food contact
- No-rinse, no-residual, continuous or on-demand sanitation
- Relative sanitizing strength - 2 PPM ozone solution is equal to 400 PPM chlorine or quaternary ammonia
- Reduces or eliminates potable water rinse steps and overall water use
- Non-corrosive sanitation solution
- No unpleasant odor

## Features of DELZONE® MPI-300

- Integrated DEL Ozone Safety Management System
- Automatic plug-and-play operation
- 3.3 GPM ozone-enriched water flow
- Dependable, reliable, low-maintenance operation
- Stainless steel, NEMA-4X enclosure
- NSF validated for anti-microbial efficacy and worker safety
- NSF registered (#132819) for hard surface sanitation
- NSF International White Book listed-proprietary substance and nonfood compound for no-rinse surface sanitation



For more information please visit us at [www.delozone.com](http://www.delozone.com)

PO Box 4905, San Luis Obispo, California, 93401

800.676.1335 ext. 238 fax: 805.541.8459

[info@delozone.com](mailto:info@delozone.com)



## Specifications

Ozone Output	2.5 grams/hr
Residual Ozone Dose at Nozzle	2.0 PPM (approx.)
Water Flow Rate	3.3 GPM
Nozzle Pressure	10 PSI
Power Requirements	115VAC, 60Hz, 7A
Supply Water Temp.	40F - 80F
Supply Water Press.	40 PSI (min)
Supply Water Flow	4 GPM (min)

## Standard Configurations

### MPI-300 (base) Ozone Surface Sanitation System

- *Wall-Mount Tabs Sold Separately (DEL part number 8-0534)*

### MPI-300WM (wall-mount) Wall-Mounted Ozone Surface Sanitation System

- *Wall-Mounted System (wall-mount tabs included)*
- *25' Ozone Delivery Hose (with quick-connect fitting to MPI-300 outlet)*
- *Short Fan Spray Wand (with ball valve & quick-connect to delivery hose)*

### MPI-300M (mobile) Mobile Ozone Surface Sanitation System

- *Carted Mobile System*
- *25' Ozone Delivery Hose (with quick-connect fitting to MPI-300 outlet)*
- *Short Fan Spray Wand (with ball valve & quick-connect to delivery hose)*
- *Garden Hose Inlet Adapter*

## Dimensions

### MPI-300WM (Wall-Mount)

Weight: 100 lbs.

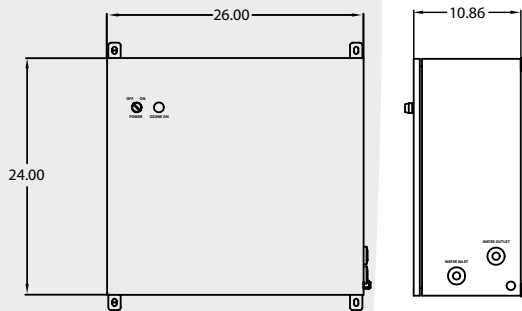

### MPI-300M (Mobile)

Weight: 125 lbs.

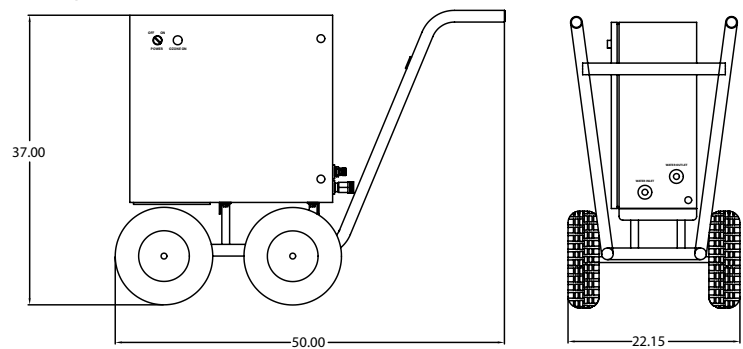

## Accessories



**MPI-0350**  
Wine Barrel Wash Wand



**MPI-0360**  
Trigger Spray Gun



**MPI-0370**  
Fan Spray Wand



**MPI-0380**  
Hot Water Protection Device  
(Installs at water inlet)

For more information please visit us at [www.delozone.com](http://www.delozone.com)

PO Box 4905, San Luis Obispo, California, 93401

800.676.1335 ext. 238 fax: 805.541.8459

o3info@delozone.com