

DEL OZONE Laboratory LG-7 and LG-14

OWNER'S MANUAL



DEL ozone™
advanced sanitation solutions

TABLE OF CONTENTS

SECTION 1

General Information

- 1A. Description 1
- 1B. Standard Features 1
- 1C. Specifications..... 1
- 1D. Warranty Summary 1
- 1E. User Interface Panel 1

SECTION 2

Installation

- 2A. Location2
- 2B Main Power2
- 2C Plumbing.....2
 - 2C-1 Standard Connections.....2
 - 2C-2 Sample Valve Connection2

SECTION 3

Operation

- 3A. Feed gas 3
 - 3A-1 Standard Operation.....3
 - 3A-2 Sample Ozone Connection (optional)3
- 3B. Startup 3
 - 3B-1 Standard Operation.....3
 - 3B-2 External Control3
 - 3B-3 Shut-Down3

SECTION 4

Maintenance & Service

- 4A. Troubleshooting..... 4
- 4B. Generating Servicing 4

SECTION 5

Appendix

- A. Safety 5
- B. Gaseous Ozone MSDS 6
- C. Aqueous Ozone MSDS 9
- D. Warranty Statement 12

CAUTIONS AND GENERAL NOTES

This manual covers the DEL Ozone CD Series Corona Discharge (CD) Ozone Generators, models LG-7 and LG-14. Any variations in system operation or configuration between these models are noted in the text. The principal difference between them is ozone production capacity. These differences are outlined in the specification section of this manual.

DEL Ozone reserves the right to make changes to the product covered in this manual to improve performance, reliability, or manufacturability. Make sure that this manual is used with the original product it was shipped with. Although every effort has been made to ensure accuracy of the information contained in this manual, DEL Ozone assumes no responsibility for inadvertent errors.

IMPORTANT SAFETY INSTRUCTIONS

READ AND FOLLOW ALL INSTRUCTIONS.

- Read this manual completely before attempting installation and/or operation.
- Install in accordance with the installation instructions.
- Connect to a grounded, grounding type receptacle only.
- **Warning** - To reduce the risk of electrical shock, replace damaged cord immediately.
- Follow all applicable electrical codes.
- Electric shock hazard. Be sure to turn power OFF and disconnect from power source before any service work is performed. Failure to do so could result in serious injury or death.
- Warning - Short term inhalation of high concentrations of ozone and long term inhalation of low concentrations of ozone can cause serious harmful physiological effects. **DO NOT** inhale ozone gas produced by this device.
- For your safety, do not store or use gasoline, chemicals or other flammable liquids or vapors near this or any other appliance.
- A spontaneous and violent ignition may occur if oil, grease or greasy substances come in contact with oxygen under pressure. These substances must be kept away from oxygen regulators, cylinder valves tubing and connections, and all other oxygen equipment.

SAVE THESE INSTRUCTIONS!

SECTION 1

General Information

1A. Description

The Del Ozone **LG-7** and **LG-14** Corona Discharge (CD) ozone generators are designed for use in rack mount or table top configurations. The LG-7 unit produces 7 g/hr of ozone while the LG-14 doubles output to 14 g/hr of ozone. The units are air-cooled and reliably produce ozone concentrations up to 5% by weight when utilizing user-supplied oxygen. The **LG-7** and **LG-14** ozone generating components are housed in an all aluminum enclosure and the controls are easy to use and view. The units feature 20kHz power supplies with ceramic tube dielectric ozone generating cells for reliable ozone operation and production.

1B. Standard Features

- Variable ozone output control (0-100%)
- 0-10 VDC panel meter
- Adjustable flowmeter
- Air-cooled
- Built-in pressure relief
- 4" pressure gauge, grade 1A (+/-1% FS accuracy)
- Lighted power switch/breaker
- Aluminum enclosure (IP30), bench top/19" EIA rack mount
- Brass/Teflon® plumbing for oxygen in port and stainless steel/Teflon® plumbing for ozone out port (standard configuration)
- Stainless steel and Teflon® plumbing (optional configuration)
- External 4-20mA ozone control (optional)
- Sample port (optional)

1C. Specifications

1B-1. Ozone Output (± 10 %)

Oxygen Feed gas

LG-7 = 7.0 g/hr (max)

LG-14 = 14.0 g/hr (max)

Clean Dry Air Feed gas

LG-7 = 1.7 g/hr

LG-14 = 3.5 g/hr

1B-2. Power Requirements

LG-7: 120V, 60Hz, 2A

LG14: 120V, 60Hz, 4A

1B-3. Weight

LG-7: 20 lbs.

LG-14: 30 lbs

1B-4. Location Requirements

Indoor, Bench top or Rack-Mountable

1D. Warranty Summary

Limited Warranty:

2 years on entire generator (providing required routine maintenance is performed) See Appendix D on page 12 for complete warranty statement.

1D. User Interface Panel - Figure 1

1. Feed gas Inlet: 1/4" Compression Fitting, Connect to Feed gas supply.
2. Ozone Outlet:
3. Flowmeter:
4. Flowmeter Valve:
5. Ozone Cell Pressure Gauge:
6. Power Switch/Breaker:
7. Ozone Output Control Knob:
8. Voltage Output Meter:
9. Sample Ozone Valve (optional):
10. Sample Ozone Outlet (optional):

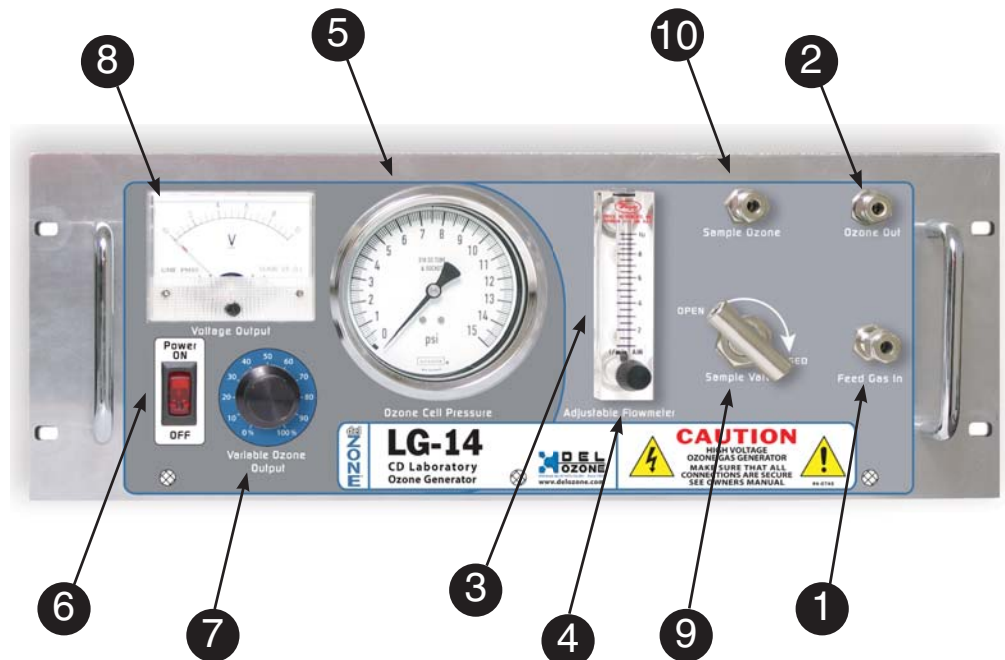

SECTION 2

Installation



WARNING: The Lab Genesis units produce ozone gas in high concentrations. Do not operate unless all plumbing connections are complete.

2A Location

The Lab Genesis units come equipped with rubber feet for Bench top use. The units are also designed to mount in a standard 19" rack mount cabinet (hardware not provided). Note: It may be necessary to remove the rubber feet from the bottom of the unit prior to rack mount installation.

2B Main Power

Use the cord provided to connect the Lab Genesis to a properly rated and grounded receptacle. If the Lab Genesis will be used where water is present, the circuit must be protected by a ground fault circuit interrupter.

2C Plumbing

2C-1 Standard Connections:

The Lab Genesis is designed to operate using customer provided Feed gas (Oxygen or Clean Dry Air.) All plumbing connections on the front panel are 1/4" OD Compression type fittings. To install tubing:

- Insert tubing (Teflon or Stainless Steel recommended), completely into the fitting.
- Hold the tubing in place and tighten the nut (about 1 1/4 turns.) The nut and ferrules are now permanently attached to the tubing.
- **Note:** For thin wall or soft plastic tubing, a tubing support insert may be required.

Connect the pressure regulated Feed gas source to the "Feed gas In" fitting on the front panel (see Figure 1.) Connect ozone analyzer, ozone destruct or process tubing to the "Ozone Out" fitting. If the process involves water circulation, a check valve should be installed in this line as well.

2C-2 Sample Valve Connection (Option):

If unit is equipped with a Sample Valve, an ozone analyzer is typically connected to the "Sample Ozone" fitting. Connect the "Ozone Out" fitting to the ozone destruct or process line. In order to control the Sample port flow, it may be necessary to add a valve to the "Ozone Out" fitting as shown in Figure 2.

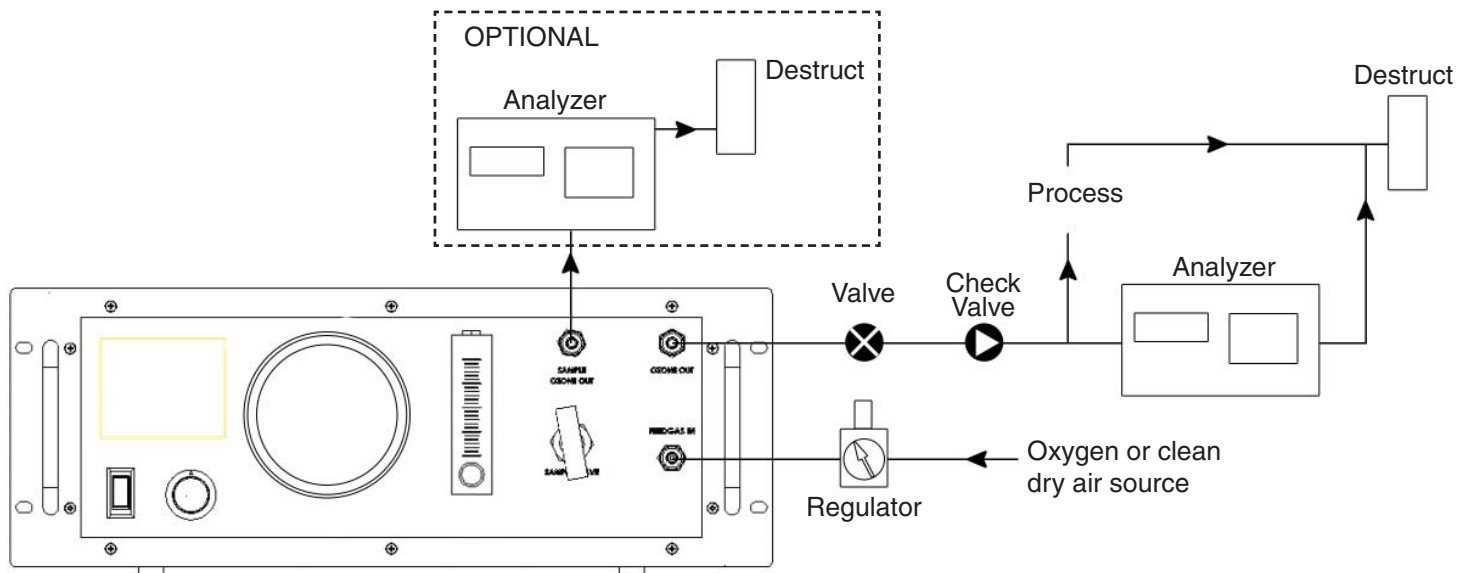

Figure 2 Lab Genesis Typical Plumbing Diagram

SECTION 3

3A. FEED GAS

3A-1. Standard Operation:

Once all of the plumbing connections have been properly made, the Lab Genesis is ready for operation. Set regulator on feed gas supply to desired pressure (15 PSIG maximum) and open any valves in the supply line.

Note: The Lab Genesis is equipped with a 15 PSI rated internal pressure relief valve to protect against damage from overpressure. The valve may begin to relieve pressure as low as 10 PSI. If a whistling sound is heard from inside the unit, check supply pressure.

Check that the Flowmeter Valve is open. Flow should begin to register on the Lab Genesis Flowmeter and the Pressure Gauge will indicate the pressure to the Ozone Cells. The Flowmeter valve can now be used to further control the feed gas delivery.

3A-2 Sample Ozone Connection (Option):

To use the optional Sample Ozone connection, make sure all the plumbing connections are made as described in Section 2. Open the Sample Valve slightly by turning it counter-clockwise and check for flow in the sample line (i.e. on the ozone analyzer.) If no flow registers, try restricting flow from the main Ozone Outlet to force flow through the Sample Outlet.

3B Start-up

3B-1 Standard Operation

Ensure that the power cord is securely connected to the back of the Lab Genesis, and turn on the Power Switch/Breaker on the front panel. The Switch should light up and the fan(s) should turn on. Increase power to the Cells by turning the Output Control knob clockwise. The Voltmeter will respond proportionally to the knob adjustment (i.e. 50% = 5VDC), as will the ozone output from the Lab Genesis.

3B-2 External Control (Optional):

If the Lab Genesis is equipped with external control, the ozone output can be adjusted using a 4-20mA signal. Connect a 4-20mA source to the removable connector on the side of the unit observing the polarity as indicated on the label (see Figure 3). Move the Control Switch from "Panel" to "4-20mA". The Voltmeter no longer responds to the Output Control knob on the front panel. The ozone output now depends on the current provided by the external source (i.e. 12mA = 50%).

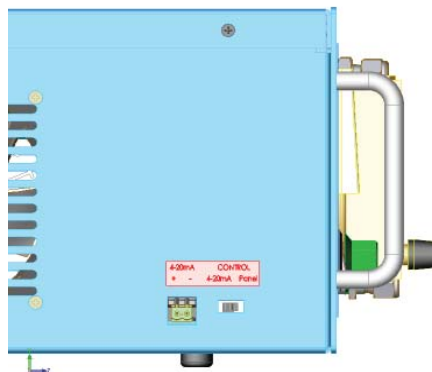

Figure 3 External Control Connector and Switch

3C Shut-Down

Prior to shutting off feed gas to the Lab Genesis, turn off the Switch/Breaker and allow the unit to purge for about 1 minute. The feed gas may now be turned off.

SECTION 4

Maintenance and Service

4A Troubleshooting

Symptom: Front Panel Switch/Breaker will not stay on.

1. Over-current condition.
 - a. Return unit for service.

Symptom: No ozone is being produced.

2. Unit is in external control mode and no current is available.
 - a. Check current source for proper operation.
 - b. Move Control Switch to "Panel".
3. Ozone Cell Thermal switches are tripped.
 - a. Shutdown Lab Genesis and allow to cool. If problem persists, return unit for service.

4B Generator Servicing

The Lab Genesis units contain no user serviceable parts. If service is required, return the unit as described in the Warranty Section.

APPENDIX “A” SAFETY

HEALTH HAZARDS OF OZONE

Detection Levels

Ozone can be detected in air by its distinctive odor at concentrations of about 0.02 ppm. Although each nose varies, olfactory fatigue occurs quickly. As a result, **DO NOT RELY ON ODOR AS A WARNING OF HIGH OZONE CONCENTRATIONS.**

The permissible exposure level (PEL) or time weighted concentration for ozone to which workers may be exposed is 0.1 ppm averaged over 8 hours, 5 days a week (OSHA). The short term exposure limit is 0.3 ppm average over 15 minutes. The concentration of 10 ppm ozone in air is generally accepted as immediately Dangerous to Life or Health (DLH).

Effects on Humans

Ozone acts as a primary irritant, affecting mainly the eyes, upper respiratory tract and the lungs. Onset of pulmonary edema (fluid buildup in the lungs) may be delayed for a few hours after exposure. Inhaling ozone at concentrations of 50 ppm for 30 minutes can be fatal. Many people exposed to airborne ozone rapidly develop a headache, which often disappears after a few minutes in fresh air.

Reduction in lung function due to scar tissue forming in the lung may occur due to long-term exposure to ozone at concentrations above 0.2 ppm, or a single high exposure. Although medical studies show no evidence of ozone causing cancer or lung allergies or harming the unborn, there is some evidence that the oxidizing power of ozone could lead to premature aging of the body as a whole.

The owner of any ozone installation should advise any person who may be exposed to ozone that those with a history of heart or respiratory disease should take every precaution to avoid exposure to ozone.

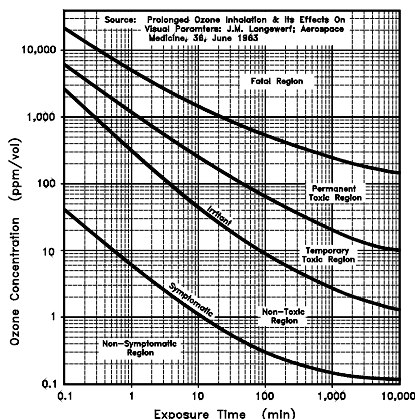

FIRST AID

General

First Action

1. If exposure to ozone causes headache or shortness of breath, immediately remove the patient to a fresh air environment.

Second Action

1. Workers who have been exposed to low concentrations of ozone should be given oxygen to breathe while under the observation of trained personnel.
2. If exposure is severe, send for medical assistance immediately.

Inhalation

First Action

1. Assess patient's breathing.
2. All unconscious patients must be placed in the drainage position (on their sides), so that fluids can drain from the airways once breathing has been restored.
3. Check pulse.

Second Action

1. If breathing has ceased, start artificial respiration (rescue breathing is the most effective) method until breathing has been restored.
2. Send for medical assistance immediately.
3. If absent, begin cardiopulmonary resuscitation (CPR).

Eye Contact

First Action

1. Effective irrigation should start immediately. Eyes should be irrigated for 30 minutes by the clock with running tap water or preferably normal saline.

Second Action

1. Effective irrigation must be continued while en route to hospital.

Precautions

Workers with a previous cardiopulmonary (heart and lung) condition must consult their physician prior to working in an area in which they may be exposed to ozone. Significant alterations in cardiopulmonary functions have been documented when such workers have been exposed to low concentration of ozone.

END OF DOCUMENT.

APPENDIX “B”

MSDS

Gaseous Version MSDS

Aqueous Version MSDS

OZONE

Material Safety Data Sheet

SECTION I: MATERIAL IDENTIFICATION

IDENTITY: OZONE (Gaseous)	ISSUED: February, 1992
FORMULA: O ₃	REVISED: March, 2009
<p>Description (origin/uses): Occurs in atmosphere from UV light action on oxygen at high altitude. Commercially obtained by passing air between electrodes carrying a high voltage alternating current. Also found as a by-product in welding areas, high voltage equipment, or UV radiation.</p> <p>Ozone is used as an oxidizing agent in air and water disinfection: for bleaching textiles, oils, and waxes; organic synthesis as in processing certain perfumes, vanillin, camphor; for mold and bacteria control in cold storage.</p>	
<p>Cautions: A powerful oxidizing agent, ozone generally exists as a gas and is highly chemically reactive. Inhalation produces various degrees of respiratory effects from irritation to pulmonary edema (fluid in lungs) as well as affecting the eyes, blood, and central nervous system.</p>	
<p>Manufacturer/Supplier: On-site generation, equipment available from various suppliers, including: DEL Ozone Phone: (805) 541-1601 3580 Sueldo Street FAX: (805) 541-8459 San Luis Obispo, CA 93401</p>	

SECTION II: INGREDIENTS AND HAZARDS

Ozone, CAS No. 10028-15-6: NIOSH RTECS No. RS8225000	
1991 OSHA PELs 8-hr TWA: 0.1 ppm vol. (0.2 mg/m ³) 15-min STEL: 0.3 ppm vol (0.6 mg/m ³) 1990 IDLH 10 ppm 1990 NIOSH REL Ceiling: 0.1 ppm vol. (0.2 mg/m ³)	1991-1992 ACGIH TLV Ceiling: 0.1 ppm (0.2 mg/m ³) 1990 DFG (Germany) MAK TWA: 0.1 ppm (0.2 mg/m ³) Category 1: Local Irritant Peak Exposure Limit: 0.2 ppm 5 min momentary value, 8 per shift
<p>Other Designations: Triatomic oxygen: CAS No. 10028-15-6, NIOSH RTECS No. RS8225000</p>	

SECTION III: PHYSICAL DATA

Boiling Point: -169° F	Melting Point: -315.4° F (-193° C)
Vapor Pressure: >1 ATM	% Volatile by Volume: 100%
Vapor Density (AIR = 1): 1.6	Molecular Weight: 48 Grams/Mole
Solubility in Water: 0.49 ml @ 32° F (0° C), 3 ppm @ 20 ° C	pH: Not Listed
	Critical Temperature: 10.22° F (-12.1° C)

Appearance and Odor: Colorless to blue gas (greater than -169° F): characteristic odor often associated with electrical sparks or lightning in concentrations of less than 2 ppm and becomes disagreeable above 1-2 ppm. CAUTION: Olfactory fatigue develops rapidly, so do not use odor as a preventative warning device.

SECTION IV: FIRE AND EXPLOSION HAZARD DATA

Flash Point: Nonflammable
Extinguishing Media: Use large amounts of water spray or fog to put out fires involving ozone. Use appropriate fire-fighting techniques to deal with surrounding material.
Special Fire Fighting Procedures: Wear a self contained breathing apparatus with full face pieces operated in a pressure-demand or other positive-pressure mode.
Unusual Fire/Explosion Hazards: Decomposition of ozone into oxygen gas, (O ₂), can increase strength of fire.

SECTION V: REACTIVITY DATA

Stability: Ozone is not stable. Hazardous polymerization cannot occur.
Chemical Incompatibilities: Ozone is chemically incompatible with all oxidizable materials, both organic and inorganic.
Conditions to Avoid: Ozone is unstable at room temperatures and spontaneously decomposes to oxygen gas. Avoid ignition sources such as heat, sparks, and open flame. Keep away from strong reducing agents and combustible materials such as grease, oils, and fats.
Products of Hazardous Decomposition: Ozone spontaneously decomposes to oxygen gas, even at room temperatures.

SECTION VI: HEALTH HAZARD DATA

Carcinogenicity: Ozone is not listed as a carcinogen by the NTP, IARC, or OSHA.

Primary Entry: Inhalation

Target Organs: Respiratory system, eyes, blood.

Summary of Risks: There is no true threshold limit and so no exposure (regardless of how small) is theoretically without effect from ozone's strong oxidative ability. Ozone passes straight to the smallest bronchioles and alveoli and is not absorbed by mucous membranes along the way. Initial small exposure may reduce cell sensitivity and/or increase mucous thickness producing a resistance to low ozone levels. Short exposure to 1-2 ppm concentrations causes headache as well as irritation to the respiratory tract but symptoms subside when exposure ends. High concentrations of ozone produce severe irritation of the eyes and respiratory tract. Exposure above the ACGIH/OSHA limits produce nausea, chest pain, coughing, fatigue, reduced visual acuity, and pulmonary edema. Symptoms of edema from excessive exposure can be delayed one or more hours. Inhalation of >20 ppm for an hour or more (>50 ppm for 1/2 hour) can be fatal.

Acute Effects: Acute damage from ozone appears to be mainly from its oxidizing effect on contact with tissue.

Chronic Effects: Respiratory disease. Deleterious effects on lungs and acceleration of tumors have been reported.

Medical Conditions Generally Aggravated by Long-Term Exposure: History of respiratory or heart disorders.

First Aid: Remove from ozone containing air, get prompt medical help*, administer oxygen if necessary.

Eye Contact - Gently lift eyelids and flush eyes continuously with flooding amounts of water for 15 minutes or until transported to a medical facility*.

Inhalation - Remove exposed person to fresh air, support breathing, administer humidified oxygen as needed, get medical help*.

Ingestion - Highly unlikely since ozone is a gas until -169° F,

* **GET MEDICAL ASSISTANCE = APPROPRIATE IN-PLANT, PARAMEDIC, or COMMUNITY.** Get prompt medical assistance for further treatment, observation, and support after first aid.

SECTION VII: PRECAUTIONS FOR SAFE HANDLING AND USE

Steps to be Taken in Case of Spill/Leak:

1. Discontinue production
2. Isolate and vent area
3. Immediately notify personnel
4. Deny entry
5. Follow applicable OSHA regulations

Disposal: Provide ventilation to dilute and disperse small amounts of ozone (below OSHA PELs) to outside atmosphere. Follow federal, state, and local regulations.

Handling/Storage Precautions: Ensure proper personnel training and establish emergency procedures.

SECTION VIII: CONTROL MEASURES

Respiratory Protection: High Level (>10 ppm) - Self Contained Breathing Apparatus: MISH/NIOSH approved.

Low Level (0.3 - 10 ppm) - Canister Type (carbon) respirator may be used.

Eye Protection: Wear chemical safety goggles if necessary to work in high ozone (>10 ppm).

Skin Protection: Effects of ozone on skin are minimal to non-existent.

Ventilation: Provide general and local exhaust ventilation to dilute & disperse small amounts of ozone into outside atmosphere.

SECTION IX: SPECIAL PRECAUTIONS AND COMMENTS

Storage Segregation: Prevent ozone from coming into direct physical contact with strong acids or bases or with strong oxidizing/reducing agents.

Engineering Controls: Install ventilation systems capable of maintaining ozone to concentrations below the ACGIH/OSHA exposure limits (see sect. II). Install ambient ozone monitor(s) configured to shut down ozone equipment and turn high speed ventilation on.

Material Safety Data Sheet

This MSDS complies with OSHA's Hazardous Communication Standard 29 CFR 1910.1200 and OSHA form 174.

DEL Ozone
3580 Sueldo Street
San Luis Obispo, CA 93401

Product Information 805-541-1601

NFPA 704 Designation Hazard Rating

4 = Extreme
 3 = High
 2 = Moderate
 1 = Slight
 0 = Insignificant

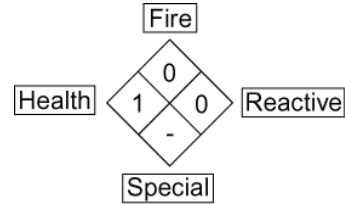

Product Name		AQUEOUS OZONE SOLUTION			
Chemical Name		DISSOLVED OZONE GAS IN WATER 0 TO 2 PPM			
Product Description		AQUEOUS SOLUTION OF OZONE DISSOLVED IN POTABLE WATER			
D.O.T. Shipping Classification		NON REGULATED			
I PHYSICAL DATA					
Boiling Point	212 F	Freezing Point	32 F		
Specific Gravity	1.0	Solubility in Water	COMPLETE		
Evaporation Rate	APPROX 1	Physical Form	LIQUID		
Appearance & Odor	COLORLESS (CLEAR) WATER WITH FRESH, ASEPTIC ODOR				
II HAZARDOUS INGREDIENTS					
MATERIAL	HAZARD	CAS #	% BY WT	ACGIH TLV	OSHA PEL
None					
III FIRE AND EXPLOSION HAZARD DATA					
Flash Point	NA	Method	NA	Auto Ign. Temp.	NA
Flammable Limits in Air	NON APPLICABLE		Lower	NA	Upper NA
Extinguishing Media	NON APPLICABLE				
Unusual Fire & Explosion Hazards	NONE				
Special Fire Fighting Procedures	NONE				

Material Safety Data Sheet Cont.

Product Name **AQUEOUS OZONE SOLUTION**

IV HEALTH HAZARD DATA	
Threshold Limit Value	NOT DETERMINED
Route of Exposure	<input type="checkbox"/> Inhalation <input type="checkbox"/> Ingestion <input type="checkbox"/> Skin <input checked="" type="checkbox"/> Eye <input checked="" type="checkbox"/> Not Hazardous
Eye Contact Hazard	Exposure may cause mild eye irritation, but is not expected.
Ingestion Hazard	Not Hazardous
Inhalation Hazard	Inhalation is not likely to be a primary route of exposure but could become irritating if aerosols are exposed to individual for extended period of time.
Skin Contact Hazard	No skin irritation is expected from short term exposure.
Skin Absorption Hazard	No published data indicates this product is absorbed through the skin.
Effects of Acute Exposure	Mild skin or eye irritation.
Effects of Chronic Exposure	Repeated exposure of the skin to concentrated product should be avoided to prevent irritation and drying of the skin.
V EMERGENCY AND FIRST AID PROCEDURES	
Eye Contact	If exposure to water containing aqueous solution of ozone causes irritation to eyes, flush eyes with plenty of clean, ozone free, running water for at least 15 minutes, lifting the upper and lower lids occasionally. Remove contact lenses if worn. Seek medical attention if irritation persists.
Skin Contact	Not likely to become irritated unless repeatedly exposed to large volumes of material. If irritation develops, rinse affected area with ozone free potable water. If irritation continues seek medical advice.
Inhalation	Inhalation of mists could lead to irritation of lungs. If symptoms develop, move individual away from exposure and into fresh air. If symptoms persist, seek medical attention.
Ingestion	NA
VI REACTIVITY DATA	
Incompatibility (Materials to Avoid)	Natural rubber (may degrade, or "dry", rubber components over extended periods of exposure)
Conditions to Avoid	NONE KNOWN
Hazardous Decomposition	NONE
Stability	<input checked="" type="checkbox"/> STABLE <input type="checkbox"/> UNSTABLE Hazardous Polymerization <input type="checkbox"/> MAY OCCUR <input checked="" type="checkbox"/> WILL NOT OCCUR

Material Safety Data Sheet Cont.

Product Name **AQUEOUS OZONE SOLUTION**

VII SPILL OR LEAK PROCEDURES				
Steps To Be Taken If Material Is Released Or Spilled		NONE		
Waste Disposal Method		DISPOSE OF THE SAME AS POTABLE RINSE WATER		
VIII SPECIAL PROTECTIVE INFORMATION				
Respiratory Protection (Specify Type)		NOT REQUIRED FOR NORMAL USE OF THIS PRODUCT		
Ventilation	Local Exhaust	PREFERABLE	Special	NA
	Mechanical (general)	OK	Other	NA
Protective Gloves	NOT REQUIRED			
Eye Protection	NOT REQUIRED			
Other Protective Equipment	NOT REQUIRED			
IX SPECIAL PRECAUTIONS				
Precautionary Labeling	<p>Certified testing of DEL Ozone systems by NSF (National Sanitation Foundation) has shown that under normal conditions of use, aqueous solutions containing low levels of ozone gas dissolved in potable water do not present a safety hazard when contact to the individual is incidental. When used in a room with normal ventilation, levels of ozone gas being released into the air have been shown by NSF to be well below the periodic exposure levels established by OSHA for worker safety through the use of DEL's ozone management technology.</p>			
Precautions To Be Taken In Handling	<p>Aqueous solutions of ozone in potable water should not be sprayed as an aerosol (i.e. >20psi) to avoid releasing higher levels of ozone gas into the work area. The decay rate of ozone gas is a function of temperature and exposure to organic material. Certified testing has shown that when ozone gas has been properly dissolved in ambient temperature (or colder (33 – 70 °F)) potable water at a level not exceeding 2 mg/l (ppm) using DEL's ozone management technology, the rate at which ozone is released from the water as ozone gas is below the PEL established for gaseous ozone.</p>			
				Rev. Date 03/26/09
<p>This material safety data sheet is provided as an information resource only. It should not be taken as a warranty or representation for which the preparer assumes legal responsibility. While we believe the information contained herein is accurate and compiled from sources believed to be reliable, it is the responsibility of the user to investigate and verify its validity. The buyer assumes all responsibility of using and handling the product in accordance with applicable federal, state, and local regulations.</p>				

APPENDIX “C”

Warranty

DEL OZONE COMMERCIAL PRODUCT LIMITED TWO YEAR WARRANTY

The limited warranty set forth below applies to products manufactured by DEL OZONE – 3580 Sueldo Street, San Luis Obispo, California 93401, and sold by DEL OZONE or its authorized dealers. This limited warranty is given only to the first retail purchaser of such products and is not transferable to any subsequent owners or purchasers of such products. Systems sized 65 grams or greater require factory commissioning and startup to maintain warranty as set forth below.

DEL OZONE warrants that DEL or DEL authorized dealers will repair or replace, at DEL’s option, any part of such products proven to be defective in materials or workmanship within two (2) years of the date of receipt. Parts are covered under the two (2) year warranty when and only when the stated maintenance requirements are met. Contact Tanks and degas valves have a ninety (90) day warranty. Compressor(s) must be maintained per operation and maintenance manual. Required maintenance includes a compressor rebuild after one (1) year or every 8,760 hours, which ever is reached first. Warranty does not include parts for compressor(s) rebuild kit(s), or other consumable items. See owner’s manual for complete maintenance details. This Warranty specifically excludes any components not manufactured by DEL OZONE that are external to the products covered, such as pumps, air compressors, monitors, tanks, or related components. DEL OZONE will assist with warranty claims for such components purchased through DEL OZONE; limited to the extent of the manufacturer’s standard warranty. ANY REPAIR OR REPLACEMENT WILL BE WARRANTED ONLY FOR THE BALANCE OF THE ORIGINAL TWO (2) YEAR WARRANTY PERIOD

NOTE: USE ONLY DEL AUTHORIZED DEL REPLACEMENT PARTS. USE OF ANY OTHER PART(S) WILL VOID THIS WARRANTY.

Any replaced parts must be returned to DEL OZONE for warranty evaluation.

THIS LIMITED WARRANTY DOES NOT INCLUDE ANY OF THE FOLLOWING:

- (a) Any labor charges for troubleshooting, removal, or installation of such parts.
- (b) Any repair or replacement of such parts necessitated by faulty installation, improper maintenance, improper operation, misuse, abuse, negligence, accident, fire, flood, repair materials, and/or unauthorized accessories.
- (c) Any such products installed without regard to required local codes and accepted trade practices.
- (d) Damage to unit caused by water backflow;
- (e) Any implied warranty of merchantability or implied warranty of fitness for particular purpose, and such warranties are hereby disclaimed.
- (f) DEL Ozone shall not be liable under any circumstances for loss of use of such product, loss of profits, direct damages, indirect damages, consequential damages, and / or incidental damages.

This warranty gives you specific legal rights. You may have other rights which vary from state to state.

Extended Warranties and Service Agreements are available. Contact DEL for additional details.

TO OBTAIN WARRANTY SERVICE:

DEL OZONE Commercial Department
 3580 Sueldo, San Luis Obispo, CA 93403
 Customer Service Number: (800) 676-1335
 Fax Number: (805) 541-8459
 E mail: service@delozone.com

PROVIDE:

1. Project, contact name, mailing address and telephone.
2. Installer/Mechanical Contractor.
3. Unit Part Number, Serial Number, and date of purchase.
4. The date of failure.
5. A description of the failure.

After this information is provided, DEL Ozone may release a *RETURN GOODS AUTHORIZATION (RGA) NUMBER*. After receiving the RGA number the part in question must be returned to DEL Ozone, freight prepaid, with the RGA number clearly marked on the outside of the package. All preauthorized defective parts must be returned to DEL Ozone within thirty (30) days. Under no circumstances may any product be returned to DEL Ozone without prior authorization. Returns without the assigned RGA number on the outside of the package will be refused and shipped back to the sender at their expense. Upon receipt of preauthorized returned goods, DEL Ozone will repair or replace, at DEL Ozone’s option, the defective product(s) and return them (freight prepaid for products under warranty). Buyer’s acceptance of the product and use thereof constitutes acceptance of these terms