GENESIS™

CORONA DISCHARGE OZONE GENERATORS

CD-15G, CD-15GV, & CD-25GV



INSTALLATION & OPERATION MANUAL

TABLE OF CONTENTS

SECTION 1

General Information

1A. Description	1
1B. Specifications	1

SECTION 2

Installation

2A. Location	1
2B. Mounting	1
2C. Electrical	2
2D. Plumbing	2

SECTION 3

Operation

3A. General	3
3B. Initial System Start-Up	3
3C. Normal Operation.....	3
3D. Shut-Down	3
3E. Water Chemistry	3

SECTION 4

Maintenance & Service

4A. System Electromechanical Overview.....	4
4B. PM Schedule.....	6
4D. Trouble Shooting	6

SECTION 5

Replacement Parts & Order Info

5A. Ordering Information	6
5B. Standard Replacement Parts List.....	6

Warranty	7
----------------	---

Appendices

Appendix A (Safety).....	8-9
Appendix B (MSDS)	10-12
Appendix C (Troubleshooting Guide)	13-17

IMPORTANT SAFETY INSTRUCTIONS

READ AND FOLLOW ALL INSTRUCTIONS.

- Read this manual completely before attempting installation.
- Install at least 5 feet (1.5meters) from wall of spa or pool water using nonmetallic plumbing. Install ozone generator no less than one (1) foot above maximum water level to prevent water from contacting electrical equipment. Install in accordance with the installation instructions.
- Connect to a grounded, grounding type receptacle only.
- Do not bury cord.
- Warning - To reduce the risk of electrical shock, replace damaged cord immediately.
- Follow all applicable electrical codes.
- Electric shock hazard. Be sure to turn power OFF and disconnect from power source before any service work is performed. Failure to do so could result in serious injury or death.
- Warning - Short term inhalation of high concentrations of ozone and long term inhalation of low concentrations of ozone can cause serious harmful physiological effects. DO NOT inhale ozone gas produced by this device.
- For your safety, do not store or use gasoline, chemicals or other flammable liquids or vapors near this or any other appliance.
- A spontaneous and violent ignition may occur if oil, grease or greasy substances come in contact with oxygen under pressure. These substances must be kept away from oxygen regulators, cylinder valves tubing and connections, and all other oxygen equipment.

SAVE THESE INSTRUCTIONS!

SECTION 1 General Information

1A. Description

The Genesis™ Corona Discharge series ozone generator described in this manual is designed to provide the benefits of ozonated water in an environmentally safe and effective manner. The high quality, specially engineered components ensure efficient ozone output and reliable performance.

As a result of proper use of the Genesis CD ozone generators, unpleasant effects of traditional chemical use, (dry skin, red eyes, green hair) are virtually eliminated. The Genesis CD ozone generator is safe and harmless to your equipment if installed properly.

1B. Specifications

Ozone Output:

Ozone output ($\pm 10\%$): CD-15G 15 g/hr
 CD-25GV... 25 g/hr
 Flow rate (max): CD-15G 13 scfh
 CD-25GV... 18 scfh
 % weight O₃: CD-15G 2.5-3%
 CD-25GV... 3.4-4%

Power Requirements:

CD-15G: 120VAC, 60 Hz, 1Ø, 8.5 Amp
 CD-25GV: 120VAC, 60 Hz, 1Ø, 10.5 Amp

Cooling Water Requirements:

0.1 GPM (.4 lpm) of clean, filtered, fresh water.

NOTE: Typical pool water may be used for cooling. Generator efficiency and life will be improved at inlet temperatures of 80°F or less.

Inlet temperature: 50°F - 90°F (10°C - 32°C)
 Inlet pressure: 15.0 - 40 psi (100 - 270 kPa)

Shipping Weight:

CD-15G: Approx. 125 pounds / 57 kilos
 CD-25GV: Approx. 130 pounds / 59 kilos

Location Requirements**:

Mounting: Floor or wall mount in a clean, protected area using supplied brackets.
 Ambient Temp: 40°F - 100°F (5°C - 40°C)
 Ventilation: Room should provide 6 air changes per hour

**Protection from weather elements must be provided for outdoor installations. Operating outside of the recommended temp. ranges may result in damage not covered under the manufacturer's warranty.

SECTION 2 Installation

2A. Location

CD-15G and CD-25GV are designed for either floor or wall mounting in a clean, protected area, either indoors or outdoors. Locate generator out of reach of sprinklers or drainage spouts. Allow sufficient access for maintenance and all tubing and electrical wires. Ozone generator should be installed no less than one foot above maximum water level.

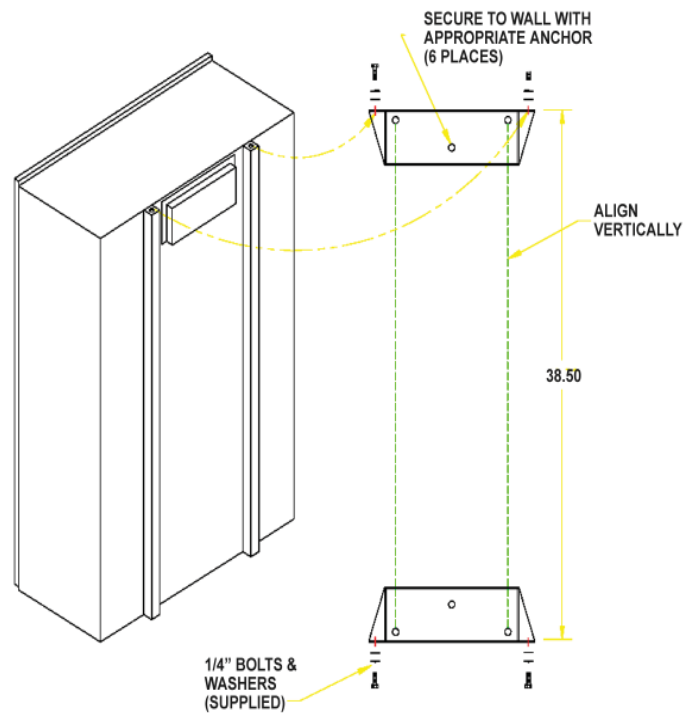

Figure 1: Wall Mount

2B. Mounting

2B-1. Wall Mount Option

1. Attach two mounting brackets to wall using anchors appropriate for mounting surface. **See figure 1.**
2. Using 1/4"-20 bolts (with washers as shown) secure generator to mounts.

2B-2. Floor Mount Option

1. Use the four 1/4"-20 bolts with washers to secure feet to bottom of cabinet.
2. Stand upright and securely fasten to concrete slab using appropriate anchors and bolts.

2C. Electrical

Main power circuit: Unit is supplied with a standard power cord. Plug cord into standard 110V grounded, grounding type receptacle only. **NOTE:** The circuit must be protected by a ground-fault circuit interrupter (GFCI) installed in accordance with electrical codes.

2D. Plumbing

Ozone gas is introduced to the pool circulation line using a venturi injector. Suction developed by the venturi allows the CD to operate safely under vacuum. *See installation manual for MX-601-XX for proper venturi installation.*

2D-1. Ozone Gas Line

1. Connect ozone tubing to generator outlet fitting. (3/8" stainless steel compression fitting.)
2. Connect opposite end of ozone tubing to injector suction port. (Suction port fitting: 3/8" stainless steel compression fitting.) *See figure 2.*

NOTE: The ozone gas supply line must be made of Teflon® or stainless steel and have a back flow prevention device (such as a check valve) installed between the ozone generator cabinet and the point of injection to prevent water from backing up into the generator system. An ozone supply check valve is included with the MX-601-XX system.

2D-2. Cooling Water

Cooling water must be supplied as specified in section 1B.

1/4" FPT connections are supplied on the generator. **See figure 2.** Be sure that the tubing is appropriately matched with the marked inlet and outlet ports. Carefully match and connect to water plumbing as shown in figure 2. Alternate method using connections at injector may be used.

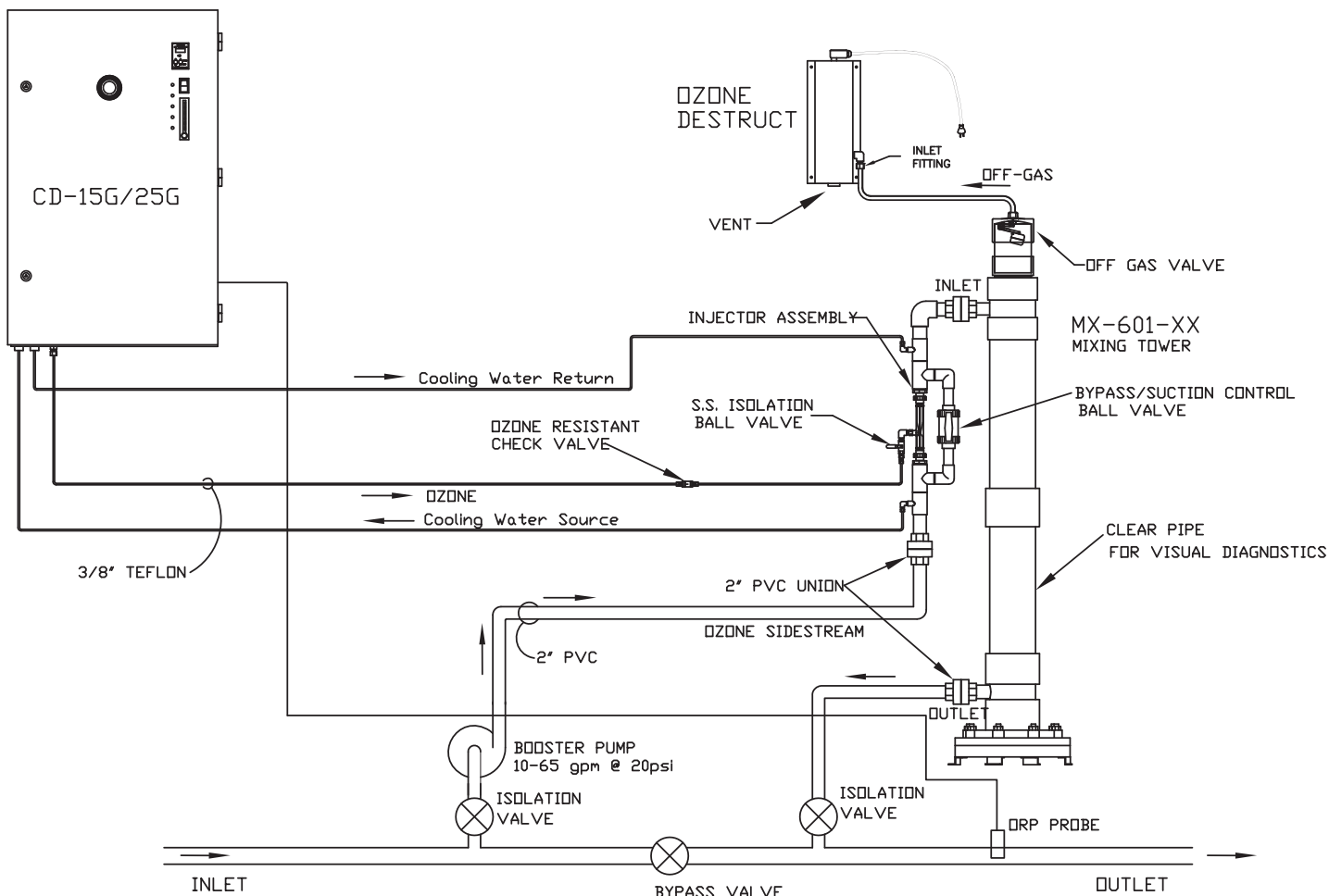

Figure 2: Plumbing Schematic

SECTION 3 Operation

3A. General

To achieve optimal performance from the ozone system, the pool must be as clean as possible to start with.

1. Backwash or clean filters one day before starting the ozone generator.
2. Superchlorinate pool water using a chlorine based shock treatment.
3. Test pool chemistry and adjust pH between 7.4 and 7.6. Adjust total alkalinity between 80 and 120 ppm.
4. Run pool filtration continuously for 24 hours prior to starting ozone system.

3B. Initial System Start-Up

Upon completing all of the generator system connections and cleaning the pool as outlined above, you are ready to begin start up procedures.

1. Check electrical fittings.
2. Check for proper voltage.
3. Turn on circulation pump.
4. Check for leaks.
5. With the ozone isolation valve closed, adjust the injector bypass valve and/or filtration sidestream valve to flow water through the injector.
6. Check cooling water.
7. Open the ozone isolation valve.
8. Turn main power switch to "ON" position.
9. Adjust injector by-pass to attain required vacuum. (Red vacuum light will go out). Gas flow at the required vacuum (read at the meter on the door) is 13 scfh for the CD-15G and CD-15GV and 17 scfh for the cd-25gv.

3C. Normal Operation

At this point, the system's cooling fans will start up. The oxygen concentrator will begin operating and the output solenoid valve will open. The ozone generator should be producing ozone and injecting it into the process line.

Both (2) **green** indicator lights should be lit. If the optional ORP Controller is installed, it should be displaying a reading from the sensor probe and will automatically cycle the generator on and off as needed to maintain water quality. Residual ORP levels will vary per application.

However, the system will not start under any of the following conditions:

1. If the optional ORP controller is installed the system will not start up if the ORP level is already above the set point of the ORP controller.
2. The system will not start up if the door is not secured. A door interlock switch is incorporated into the system enclosure.
3. The system will not start up if there is not enough vacuum being generated by water flow through injector. Red vacuum light will go out when proper vacuum is attained.

If you experience complications, see APPENDIX "C", TROUBLESHOOTING GUIDE, or call 800-676-1335 for assistance.

3D. System Shut-Down

The Genesis Corona Discharge ozone generator is a specialized water cooled device that must be properly protected during shut-down/storage periods. The following sequence of steps must be used for servicing or for storage.

1. Toggle the main system power switch to the "OFF" position to shut down generator.
2. Close the ozone isolation valve to prevent water back flow.
3. After the generator has been shut down, the process water circulation pump may be turned off.
4. If the system is going to be shutdown and stored during freezing weather, it is very important that the cooling water jacket be drained to protect it from rupture or damage.

NOTE: Process water flow *must not* be shut down when the ozone generator is operating. Doing so may cause water to back flow into the system and damage the generator module and electrodes.

3E. Water Chemistry (Swimming Pools/Spas)

Regular chlorine/bromine testing should be performed as normal. Ozone will be eliminating the majority of contaminants. Therefore, only a small amount of chemicals will need to be added - just enough to maintain a minimum of residual level of chlorine per local code requirements. Ozone has very little if any impact on pH, reducing pH adjustments to a minimum.

SECTION 4

Maintenance and Service

4A. System Electromechanical Overview

Refer to *Figure 4* for component locations.

4A-1. Indicator Lights

1. **Main Power:** Green light indicates that power is being supplied to the ozone generator.
2. **Ozone Power:** Green light indicates that power is being supplied to the high voltage Corona Discharge circuits and that ozone is being produced.
3. **Vacuum:** Red light indicates proper vacuum being supplied from the venturi injector. Light will be lit for either low or high vacuum conditions.
4. **High Coolant Temperature:** Red light indicates coolant temperature is over 110°F - resulting from loss of cooling water flow. (Refer to APPENDIX "C", TROUBLESHOOTING GUIDE.)
5. **Water Back Flow Detected:** Red light indicates water back flow from injector into generator. (Refer to APPENDIX "C", TROUBLESHOOTING GUIDE.)

4A-2. External Components

1. **Main Power Switch:** Power switch is used for system start-up and shut-down, Switch activates the control system allowing the generator to start up.
2. **Flowmeter:** Flowmeter controls and indicates the oxygen flow through the system.
3. **Circuit Breaker:** Circuit breaker protects the generator from over current conditions. Push the breaker button to reset.

4A-3. Variable Output Control

1. **Variable Output Switch (Optional):** Adjusts high voltage power supplied to the ozone generator module controlling ozone output concentration. Located on the outside of the enclosure door.

4A-4. External Devices That Control Ozone Production.

These devices turn ozone production on or off based on programmed level set points. Refer to *Figure 5* for connection details.

1. **ORP Controller (optional):** The ORP controller receives a millivolt (mV) signal from the ORP sensor mounted in the process water line. ORP (Oxygen-Reduction Potential) is a measure of the relative oxidation strength of the water. As ozone is added to the water system the ORP level will rise. As ozone is used up in the water system the ORP level will drop. The ORP controller continuously analyzes the sensor signal, compares it to the set point that has been programmed, indicates the ORP level on the digital display, and relays the signal to the ozone generator.

2. **Dissolved Ozone Monitor (optional):** Del Part Number 9-0672 and 9-0580 are on-line monitoring systems designed for the continuous measurement of ozone gas in solution. The operating range of the system may be selected by the user from 0-2.00 PPM or from 0-20.00 PPM. The basic sensing element used is polarographic membrane sensor which measures ozone directly.

4A-5. External Devices That Control System Power.

These devices turn power to the ozone generator on or off. Examples of such devices would be an ambient ozone monitor or flow switch. Refer to *figure 5* for connection details.

4A-6. Internal Components

1. **Corona Discharge (CD) Cell:** Cells are made of two aluminum halves. Enclosed in the aluminum halves are a ceramic tube, coil type high voltage electrode and a Teflon® rod.
2. **High Voltage Supply(s):** Power supplies raise incoming line voltage and frequency to deliver it to the cells. Power supplies are rated at 100W.
3. **Air Compressor:** Compressor produces and supplies compressed air to oxygen concentrator.
4. **Oxygen Concentrator:** Supplies concentrated, dry, oxygen feed gas to the ozone generator.
5. **Low Limit Vacuum Switch:** If the vacuum in the ozone output supply line falls below 1.5 in. Hg the switch will open causing the system to shut down.
6. **Vacuum Regulator:** Regulates the oxygen flow into the generator cell based on a vacuum set point (factory set to 3-5 in. Hg). When the sufficient suction is being developed by the injectors downstream the regulator will allow full flow to pass. As suction is reduced, flow is restricted proportionally to maintain the vacuum set point. If suction is lost completely, flow is cut off.
7. **Water Back Flow Detector:** The back flow detector senses water present in ozone tubing in generator. If water is detected, system will close solenoid valve to prevent additional water back flow from occurring. Water in the generator will cause severe damage to the high voltage electrodes.
8. **Ventilation Fan:** Cooling fan operates when main power switch is "ON".
9. **Air Filter:** Filter cleans ventilation air entering the enclosure.
10. **Door Interlock Switch:** Interlock switch will shut down entire system if door is opened. Securing the door will bring the system back into operation.
11. **Relay Panel:** Contains control relays for system interlocks, indicator lights and main power control.
12. **Hour Meter:** Indicates total system operating time in hours.

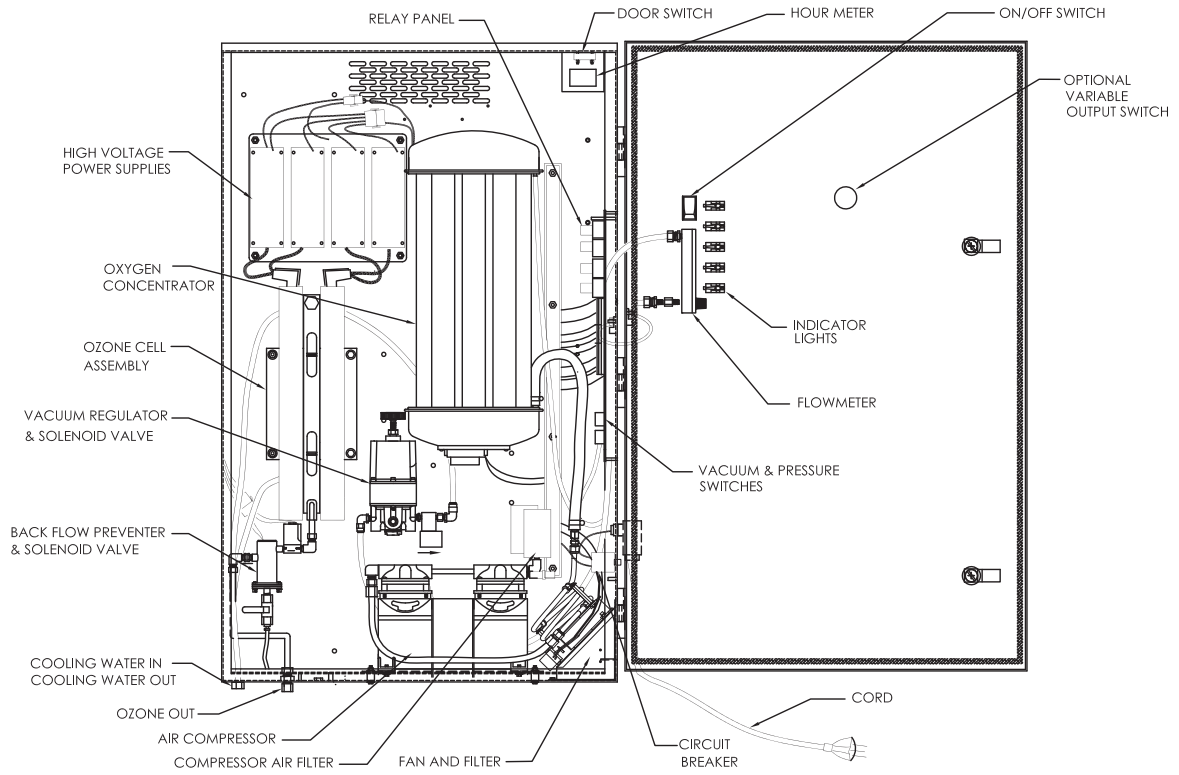

Figure 4: Component Locations

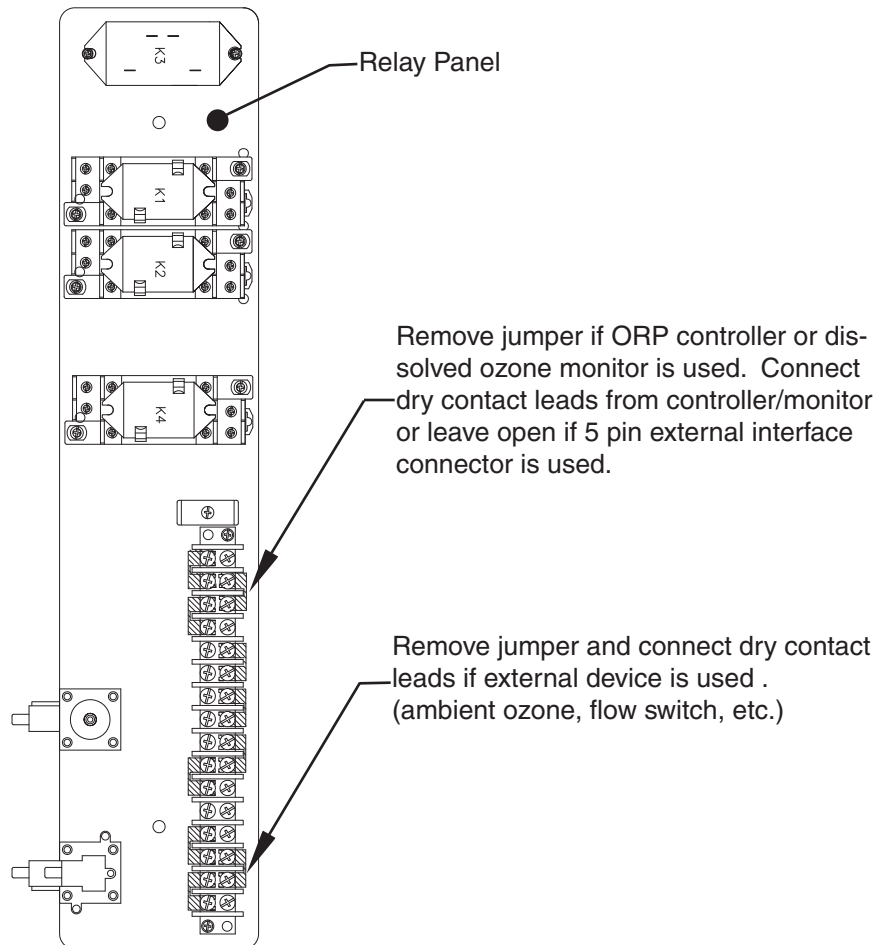

Figure 5: Connection Details for External Control Devices

4B. Preventive Maintenance Schedule

Regular maintenance should be performed to avoid damage to the system, more costly repairs and to keep the warranty active. For instance, the compressor should be rebuilt every 8,750 hours to prevent the reduction in pressure and flow. If the compressor is not rebuilt, oxygen concentrator sieve beds will become plugged and unusable, creating more costly problems. If the generator cells are not cleaned or replaced annually, a lower ozone output will result.

DAILY:

1. Check ozone generator for proper operation.
 - Make sure no red indicator lights are lit.
 - Make sure flow meter is indicating proper air flow.
2. Practice normal pool maintenance.

MONTHLY:

1. Inspect Compressor air filter.
 - Replace Quarterly
2. Remove and clean cabinet air filter (see Figure 6).
 - Remove filter housing to access filter.
 - Rinse filter in warm, soapy water and blow dry.
 - Replace filter.
3. Remove and clean ORP probe (if present).
 - Remove from water stream.
 - Clean tip of probe with non-abrasive cleanser to remove any contaminant build up on probe.
 - If there is a heavy build up on probe surface, clean with a mild muriatic solution.
 - Rinse and return to water stream
4. Perform general cleaning of cabinet interior.

EVERY 8,750 HOURS:

1. Rebuild compressor. Kit Available. See Section 5 for ordering information.
2. Replace/Service Check Valve(s) and Solenoid Valves.

EVERY 17,500 HOURS:

1. Replace CD ozone cells (two required for CD-15G, four required for CD-25GV). See SECTION 5 for ordering information.

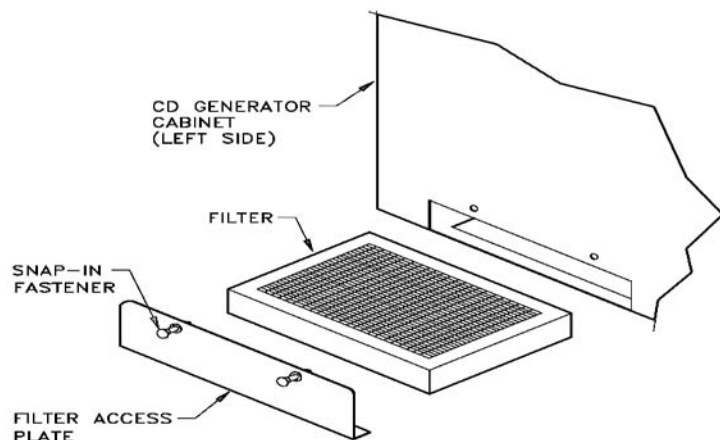

Figure 6: Filter Replacement

4D. Trouble Shooting

See APPENDIX "C", TROUBLESHOOTING GUIDE

NOTE: Knowledge of electrical applications is required for troubleshooting. Contact a certified electrician if you are unsure of your ability to service the equipment.

If any condition persists, call 800-676-1335 for technical assistance.

SECTION 5

Replacement Parts and Order Information

5A. Ordering information:

For replacement parts call DEL at **1-800-676-1335**.

Be prepared with the following information:

- Customer Name · Customer Address
- DEL Model Number · DEL Serial Number
- Date Purchased · Proof of Purchase

5B. Standard replacement parts list:

1. Compressor Air Filter Element7-1120
2. Compressor rebuild kit.....2-1025
 - CD-25GV-97 2-0930-01
3. CD Ozone Cell.....9-0927
4. Cell O-rings7-0461
5. Cabinet Air Filter..... 7-1321-01
6. Ozone Check Valve8-0330
7. Indicator Light (Green).....5-0241
8. Indicator Light (Red).....5-0058
9. Pressure Switch.....5-0835
10. Vacuum Switch5-0752/a
11. Relay, 30 Amp5-1263
12. BFPD Gasket..... 7-0826-01
13. Oxygen Concentrator5-1022
14. Ozone tubing, Teflon®7-0126
15. Ozone tubing, Stainless Steel8-0098
16. Installation & Operations Manual.....4-0558
17. Door Key..... 2-0015/key

DEL OZONE COMMERCIAL PRODUCT LIMITED TWO YEAR WARRANTY

The limited warranty set forth below applies to products manufactured by DEL OZONE – 3580 Sueldo Street, San Luis Obispo, California 93401, and sold by DEL OZONE or its authorized dealers. This limited warranty is given only to the first retail purchaser of such products and is not transferable to any subsequent owners or purchasers of such products. Systems sized 65 grams or greater require factory commissioning and startup to maintain warranty as set forth below.

DEL OZONE warrants that DEL or DEL authorized dealers will repair or replace, at DEL's option, any part of such products proven to be defective in materials or workmanship within two (2) years of the date of receipt. Parts are covered under the two (2) year warranty when and only when the stated maintenance requirements are met. Contact Tanks and degas valves have a ninety (90) day warranty. Compressor(s) must be maintained per operation and maintenance manual. Required maintenance includes a compressor rebuild after one (1) year or every 8,760 hours, which ever is reached first. Warranty does not include parts for compressor(s) rebuild kit(s), or other consumable items. See owner's manual for complete maintenance details. This Warranty specifically excludes any components not manufactured by DEL OZONE that are external to the products covered, such as pumps, air compressors, monitors, tanks, or related components. DEL OZONE will assist with warranty claims for such components purchased through DEL OZONE; limited to the extent of the manufacturer's standard warranty. ANY REPAIR OR REPLACEMENT WILL BE WARRANTED ONLY FOR THE BALANCE OF THE ORIGINAL TWO (2) YEAR WARRANTY PERIOD

NOTE: USE ONLY DEL AUTHORIZED DEL REPLACEMENT PARTS. USE OF ANY OTHER PART(S) WILL VOID THIS WARRANTY.

Any replaced parts must be returned to DEL OZONE for warranty evaluation.

THIS LIMITED WARRANTY DOES NOT INCLUDE ANY OF THE FOLLOWING:

- (a) Any labor charges for troubleshooting, removal, or installation of such parts.
- (b) Any repair or replacement of such parts necessitated by faulty installation, improper maintenance, improper operation, misuse, abuse, negligence, accident, fire, flood, repair materials, and/or unauthorized accessories.
- (c) Any such products installed without regard to required local codes and accepted trade practices.
- (d) Damage to unit caused by water backflow;
- (e) Any implied warranty of merchantability or implied warranty of fitness for particular purpose, and such warranties are hereby disclaimed.
- (f) DEL Ozone shall not be liable under any circumstances for loss of use of such product, loss of profits, direct damages, indirect damages, consequential damages, and / or incidental damages.

This warranty gives you specific legal rights. You may have other rights which vary from state to state.

Extended Warranties and Service Agreements are available. Contact DEL for additional details.

TO OBTAIN WARRANTY SERVICE:

DEL OZONE Commercial Department
PO Box 4509, San Luis Obispo, CA 93403
Customer Service Number: (800) 676-1335
Fax Number: (805) 541-8459
E mail: service@delozone.com

PROVIDE:

- 1. Project, contact name, mailing address and telephone.**
- 2. Installer/Mechanical Contractor.**
- 3. Unit Part Number, Serial Number, and date of purchase.**
- 4. The date of failure.**
- 5. A description of the failure.**

After this information is provided, DEL Ozone may release a *RETURN GOODS AUTHORIZATION (RGA) NUMBER*. After receiving the RGA number the part in question must be returned to DEL Ozone, freight prepaid, with the RGA number clearly marked on the outside of the package. All preauthorized defective parts must be returned to DEL Ozone within thirty (30) days. Under no circumstances may any product be returned to DEL Ozone without prior authorization. Returns without the assigned RGA number on the outside of the package will be refused and shipped back to the sender at their expense. Upon receipt of preauthorized returned goods, DEL Ozone will repair or replace, at DEL Ozone's option, the defective product(s) and return them (freight prepaid for products under warranty). Buyer's acceptance of the product and use thereof constitutes acceptance of these terms

APPENDIX “A” SAFETY

HEALTH HAZARDS OF OZONE

Detection Levels

Ozone can be detected in air by its distinctive odor at concentrations of about 0.02 ppm. Although each nose varies, olfactory fatigue occurs quickly. As a result, **DO NOT RELY ON ODOR AS A WARNING OF HIGH OZONE CONCENTRATIONS.**

The permissible exposure level (PEL) or time weighted concentration for ozone to which workers may be exposed is 0.1 ppm averaged over 8 hours, 5 days a week (OSHA). The short term exposure limit is 0.3 ppm average over 15 minutes. The concentration of 10 ppm ozone in air is generally accepted as immediately Dangerous to Life or Health (DLH).

Effects on Humans

Ozone acts as a primary irritant, affecting mainly the eyes, upper respiratory tract and the lungs. Onset of pulmonary edema (fluid buildup in the lungs) may be delayed for a few hours after exposure. Inhaling ozone at concentrations of 50 ppm for 30 minutes can be fatal. Many people exposed to airborne ozone rapidly develop a headache, which often disappears after a few minutes in fresh air.

Reduction in lung function due to scar tissue forming in the lung may occur due to long-term exposure to ozone at concentrations above 0.2 ppm, or a single high exposure. Although medical studies show no evidence of ozone causing cancer or lung allergies or harming the unborn, there is some evidence that the oxidizing power of ozone could lead to premature aging of the body as a whole.

The owner of any ozone installation should advise any person who may be exposed to ozone that those with a history of heart or respiratory disease should take every precaution to avoid exposure to ozone.

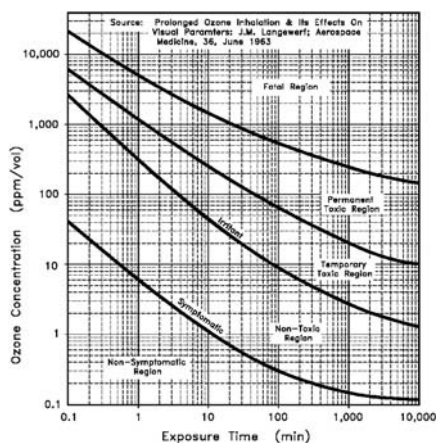

FIRST AID

General

First Action

1. If exposure to ozone causes headache or shortness of breath, immediately remove the patient to a fresh air environment.

Second Action

1. Workers who have been exposed to low concentrations of ozone should be given oxygen to breathe while under the observation of trained personnel.
2. If exposure is severe, send for medical assistance immediately.

Inhalation

First Action

1. Assess patient's breathing.
2. All unconscious patients must be placed in the drainage position (on their sides), so that fluids can drain from the airways once breathing has been restored.
3. Check pulse.

Second Action

1. If breathing has ceased, start artificial respiration (rescue breathing is the most effective) method until breathing has been restored.
2. Send for medical assistance immediately.
3. If absent, begin cardiopulmonary resuscitation (CPR).

Eye Contact

First Action

1. Effective irrigation should start immediately. Eyes should be irrigated for 30 minutes by the clock with running tap water or preferably normal saline.

Second Action

1. Effective irrigation must be continued while en route to hospital.

Precautions

Workers with a previous cardiopulmonary (heart and lung) condition must consult their physician prior to working in an area in which they may be exposed to ozone. Significant alterations in cardiopulmonary functions have been documented when such workers have been exposed to low concentration of ozone.

END OF DOCUMENT.

APPENDIX “B” MSDS

OZONE**Material Safety Data Sheet****SECTION I: MATERIAL IDENTIFICATION**

IDENTITY: OZONE (Gaseous)	ISSUED: February, 1992
FORMULA: O ₃	REVISED: March, 2009
Description (origin/uses): Occurs in atmosphere from UV light action on oxygen at high altitude. Commercially obtained by passing air between electrodes carrying a high voltage alternating current. Also found as a by-product in welding areas, high voltage equipment, or UV radiation. Ozone is used as an oxidizing agent in air and water disinfection: for bleaching textiles, oils, and waxes; organic synthesis as in processing certain perfumes, vanillin, camphor; for mold and bacteria control in cold storage.	
Cautions: A powerful oxidizing agent, ozone generally exists as a gas and is highly chemically reactive. Inhalation produces various degrees of respiratory effects from irritation to pulmonary edema (fluid in lungs) as well as affecting the eyes, blood, and central nervous system.	
Manufacturer/Supplier: On-site generation, equipment available from various suppliers, including: DEL Ozone Phone: (805) 541-1601 3580 Sueldo Street FAX: (805) 541-8459 San Luis Obispo, CA 93401	

SECTION II: INGREDIENTS AND HAZARDS

Ozone, CAS No. 10028-15-6: NIOSH RTECS No. RS8225000	
1991 OSHA PELs 8-hr TWA: 0.1 ppm vol. (0.2 mg/m ³) 15-min STEL: 0.3 ppm vol (0.6 mg/m ³)	1991-1992 ACGIH TLV Ceiling: 0.1 ppm (0.2 mg/m ³)
1990 IDLH 10 ppm	1990 DFG (Germany) MAK TWA: 0.1 ppm (0.2 mg/m ³) Category 1: Local Irritant Peak Exposure Limit: 0.2 ppm 5 min momentary value, 8 per shift
1990 NIOSH REL Ceiling: 0.1 ppm vol. (0.2 mg/m ³)	
Other Designations: Triatomic oxygen: CAS No. 10028-15-6, NIOSH RTECS No. RS8225000	

SECTION III: PHYSICAL DATA

Boiling Point: -169° F	Melting Point: -315.4° F (-193° C)
Vapor Pressure: >1 ATM	% Volatile by Volume: 100%
Vapor Density (AIR = 1): 1.6	Molecular Weight: 48 Grams/Mole
Solubility in Water: 0.49 ml @ 32° F (0° C), 3 ppm @ 20° C	pH: Not Listed
	Critical Temperature: 10.22° F (-12.1° C)

Appearance and Odor: Colorless to blue gas (greater than -169° F): characteristic odor often associated with electrical sparks or lightning in concentrations of less than 2 ppm and becomes disagreeable above 1-2 ppm. CAUTION: Olfactory fatigue develops rapidly, so do not use odor as a preventative warning device.

SECTION IV: FIRE AND EXPLOSION HAZARD DATA

Flash Point: Nonflammable
Extinguishing Media: Use large amounts of water spray or fog to put out fires involving ozone. Use appropriate fire-fighting techniques to deal with surrounding material.
Special Fire Fighting Procedures: Wear a self contained breathing apparatus with full face pieces operated in a pressure-demand or other positive-pressure mode.
Unusual Fire/Explosion Hazards: Decomposition of ozone into oxygen gas, (O ₂), can increase strength of fire.

SECTION V: REACTIVITY DATA

Stability: Ozone is not stable. Hazardous polymerization cannot occur.
Chemical Incompatibilities: Ozone is chemically incompatible with all oxidizable materials, both organic and inorganic.
Conditions to Avoid: Ozone is unstable at room temperatures and spontaneously decomposes to oxygen gas. Avoid ignition sources such as heat, sparks, and open flame. Keep away from strong reducing agents and combustible materials such as grease, oils, and fats.
Products of Hazardous Decomposition: Ozone spontaneously decomposes to oxygen gas, even at room temperatures.

4-0697_ Rev.B

SECTION VI: HEALTH HAZARD DATA

Carcinogenicity: Ozone is not listed as a carcinogen by the NTP, IARC, or OSHA.

Primary Entry: Inhalation

Target Organs: Respiratory system, eyes, blood.

Summary of Risks: There is no true threshold limit and so no exposure (regardless of how small) is theoretically without effect from ozone's strong oxidative ability. Ozone passes straight to the smallest bronchioles and alveoli and is not absorbed by mucous membranes along the way. Initial small exposure may reduce cell sensitivity and/or increase mucous thickness producing a resistance to low ozone levels. Short exposure to 1-2 ppm concentrations causes headache as well as irritation to the respiratory tract. but symptoms subside when exposure ends. High concentrations of ozone produce severe irritation of the eyes and respiratory tract. Exposure above the ACGIH/OSHA limits produce nausea, chest pain, coughing, fatigue, reduced visual acuity, and pulmonary edema. Symptoms of edema from excessive exposure can be delayed one or more hours. Inhalation of >20 ppm for an hour or more (>50 ppm for 1/2 hour) can be fatal.

Acute Effects: Acute damage from ozone appears to be mainly from its oxidizing effect on contact with tissue.

Chronic Effects: Respiratory disease. Deleterious effects on lungs and acceleration of tumors have been reported.

Medical Conditions Generally Aggravated by Long-Term Exposure: History of respiratory or heart disorders.

First Aid: Remove from ozone containing air, get prompt medical help*, administer oxygen if necessary.

Eye Contact - Gently lift eyelids and flush eyes continuously with flooding amounts of water for 15 minutes or until transported to a medical facility*.

Inhalation - Remove exposed person to fresh air, support breathing, administer humidified oxygen as needed, get medical help*.

Ingestion - Highly unlikely since ozone is a gas until -169° F,

* **GET MEDICAL ASSISTANCE = APPROPRIATE IN-PLANT, PARAMEDIC, or COMMUNITY.** Get prompt medical assistance for further treatment, observation, and support after first aid.

SECTION VII: PRECAUTIONS FOR SAFE HANDLING AND USE

Steps to be Taken in Case of Spill/Leak:

1. Discontinue production
2. Isolate and vent area
3. Immediately notify personnel
4. Deny entry
5. Follow applicable OSHA regulations

Disposal: Provide ventilation to dilute and disperse small amounts of ozone (below OSHA PELs) to outside atmosphere. Follow federal, state, and local regulations.

Handling/Storage Precautions: Ensure proper personnel training and establish emergency procedures.

SECTION VIII: CONTROL MEASURES

Respiratory Protection: High Level (>10 ppm) - Self Contained Breathing Apparatus: MISH/NIOSH approved.

Low Level (0.3 - 10 ppm) - Canister Type (carbon) respirator may be used.

Eye Protection: Wear chemical safety goggles if necessary to work in high ozone (>10 ppm).

Skin Protection: Effects of ozone on skin are minimal to non-existent.

Ventilation: Provide general and local exhaust ventilation to dilute & disperse small amounts of ozone into outside atmosphere.

SECTION IX: SPECIAL PRECAUTIONS AND COMMENTS

Storage Segregation: Prevent ozone from coming into direct physical contact with strong acids or bases or with strong oxidizing/reducing agents.

Engineering Controls: Install ventilation systems capable of maintaining ozone to concentrations below the ACGIH/OSHA exposure limits (see sect. II). Install ambient ozone monitor(s) configured to shut down ozone equipment and turn high speed ventilation on.

APPENDIX “C” TROUBLESHOOTING GUIDE



**TROUBLESHOOTING GUIDE
FOR DEL OZONE CD-15G & 25G SERIES
OZONE GENERATORS**

This document is a guide to help troubleshoot problems that might arise in operation of the DEL Ozone CD-15G & 25G Series ozone generators. It contains three main sections that when used together provide a basic overview of the ozone generator layout, troubleshooting table for common problems, and electrical, pneumatic, and hydraulic order diagrams. If you still need help, call our **Commercial Service Department at 1-800-676-1335**.

Note: Always disconnect the ozone generator from the power source before attempting service or repair.

Image 1: Ozone Generator Component Locations (CD-25GV model shown)

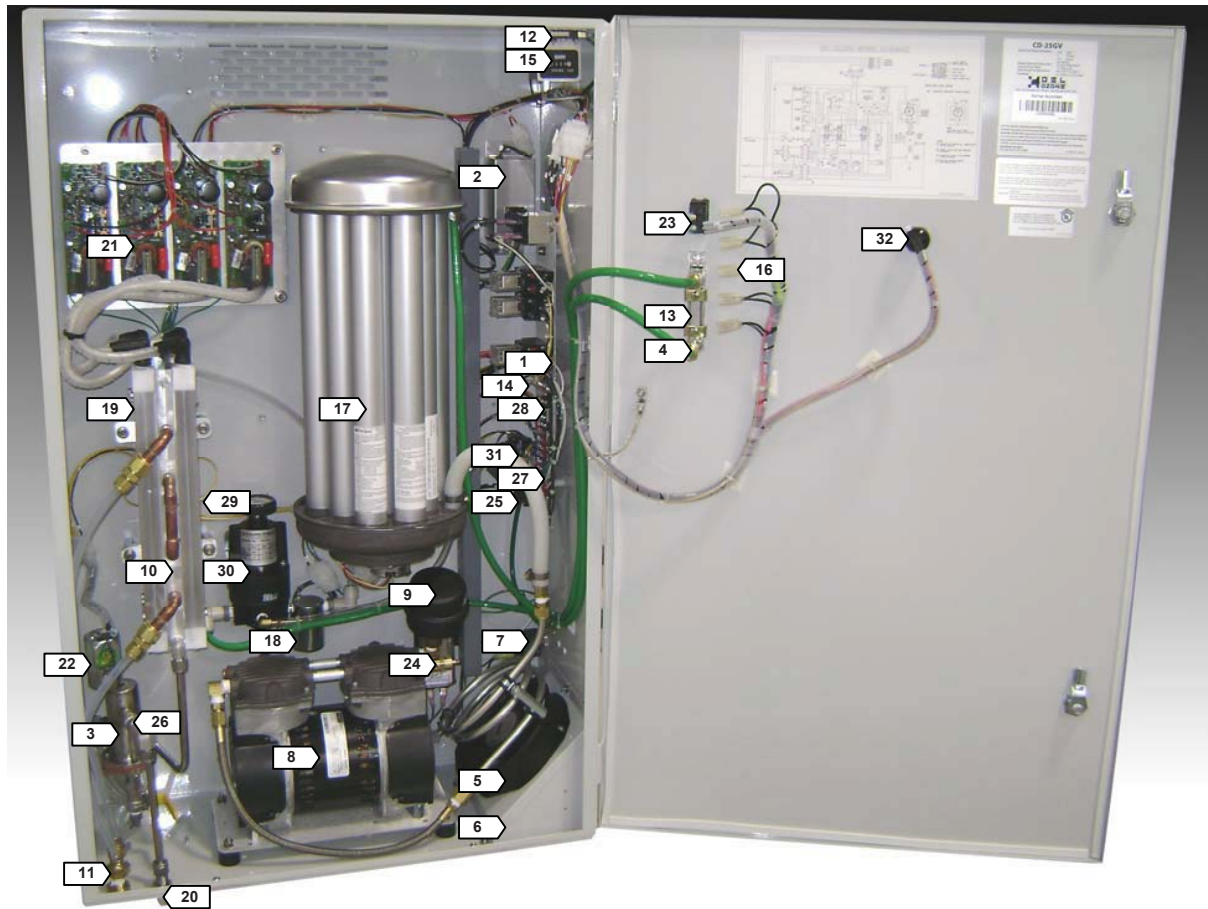

1. 5-Pin connector (not shown)	12. Door switch	23. Power switch
2. 12VDC power supply (optional)	13. Flowmeter	24. Pressure relief valve
3. Backflow prevention device (BFPD)	14. Fuse	25. Pressure switch
4. Brass orifice	15. Hourmeter	26. S.S. check valve
5. Cabinet fan	16. Indicator lights	27. Terminal block 1 (TB1)
6. Cabinet filter (not shown)	17. Oxygen concentrator	28. Terminal block 4 (TB4)
7. Circuit breaker	18. Oxygen solenoid valve	29. Thermal switch (not shown)
8. Compressor	19. Ozone cells	30. Vacuum regulator
9. Compressor air filter	20. Ozone output fitting	31. Vacuum switch
10. Cooling block assembly	21. Ozone power supplies	32. Variable ozone output control (optional)
11. Cooling water in & out fittings	22. Ozone solenoid valve	

Table 1: Troubleshooting (for best results follow the table order)

Problem (Indication)	Possible Cause	Corrective Action
1. Unit does not start (main power light is off and no sound is coming from the unit)	a. Unit is not supplied power	Connect unit to power source Turn power source breaker on Reset power source G.F.C.I. Verify power source voltage is within unit specification
	b. Unit door switch is open	Close unit door
	c. Unit power switch is in off position	Turn power switch on
	d. Unit circuit breaker is tripped	Reset circuit breaker
2. Unit is in vacuum fault (vacuum light is on)	a. Inadequate vacuum is supplied to unit	Connect unit to vacuum source (injector) Adjust injector to provide more vacuum Fix leak or obstruction in plumbing between injector and unit
	b. Unit S.S. check valve has failed	Clean or replace S.S. check valve
	c. Unit vacuum switch has failed	Replace vacuum switch
	d. Unit vacuum regulator requires adjustment or has failed	Call service department for assistance
3. Unit is in high temperature fault (high coolant temperature light is on)	a. Unit thermal switch has tripped	Reduce supplied cooling water temperature and/or increase flow rate Obstruction or scaling in cooling block assembly (clean or replace)
	b. Unit thermal switch has failed	Replace thermal switch
4. Unit is in backflow fault (water backflow detected light is on)	a. Water has returned from injection point and triggered unit back flow float switch	Disconnect ozone line between injector and unit at ozone output fitting, drain BFPD vessel, and replace SS check valve
5. Unit does not flow gas (flowmeter at bottom of scale)	a. Unit flowmeter valve is closed	Adjust flowmeter valve open
	b. Unit jumper(s) at TB1 are removed (optional system control hookup, e.g. flow switch and/or ambient O3)	Re-install jumper(s) and/or verify system control(s) are operational
	c. Unit fuse is blown	Replace fuse
	d. Unit pressure switch is not active	Verify unit plumbing between oxygen concentrator and pressure switch is securely connected
		Replace compressor air filter
		Rebuild compressor
	e. Unit orifice is plugged	Replace oxygen concentrator
	f. Unit solenoid valve(s) has failed	Clean or replace orifice
	g. Unit flowmeter ball is stuck on bottom of sight tube	Clean or replace solenoid valve(s)
h. Unit flowmeter ball is stuck on bottom of sight tube	Repair or replace flowmeter	
i. Unit vacuum regulator requires adjustment or has failed	Call service department for assistance	
6. Unit ozone production does not start (both ozone power and vacuum lights are off)	a. Unit jumper at TB4 is removed (optional external ozone control hookup, e.g. ORP or dissolved O3, directly wired or through 5-Pin)	Re-install jumper and/or verify external ozone control is operational
7. Unit does not provide effective sanitation (both main power and ozone power lights are on)	a. Unit variable ozone output control setting is too low (optional feature)	If so equipped, increase ozone output setting
	b. Leak in plumbing that dilutes applied ozone dose	Fix leak in plumbing (inside unit and/or between unit and injector)
	c. Low gas flow and/or low oxygen concentration	Replace unit compressor air filter
		Clean or replace unit orifice
		Clean or replace unit check valve
	d. Unit ozone cell has reached service life or failed	Rebuild unit compressor
e. Unit ozone power supply has failed	Replace unit oxygen concentrator	
		Replace ozone cell
		Replace power supply

Electrical Component Order Diagram

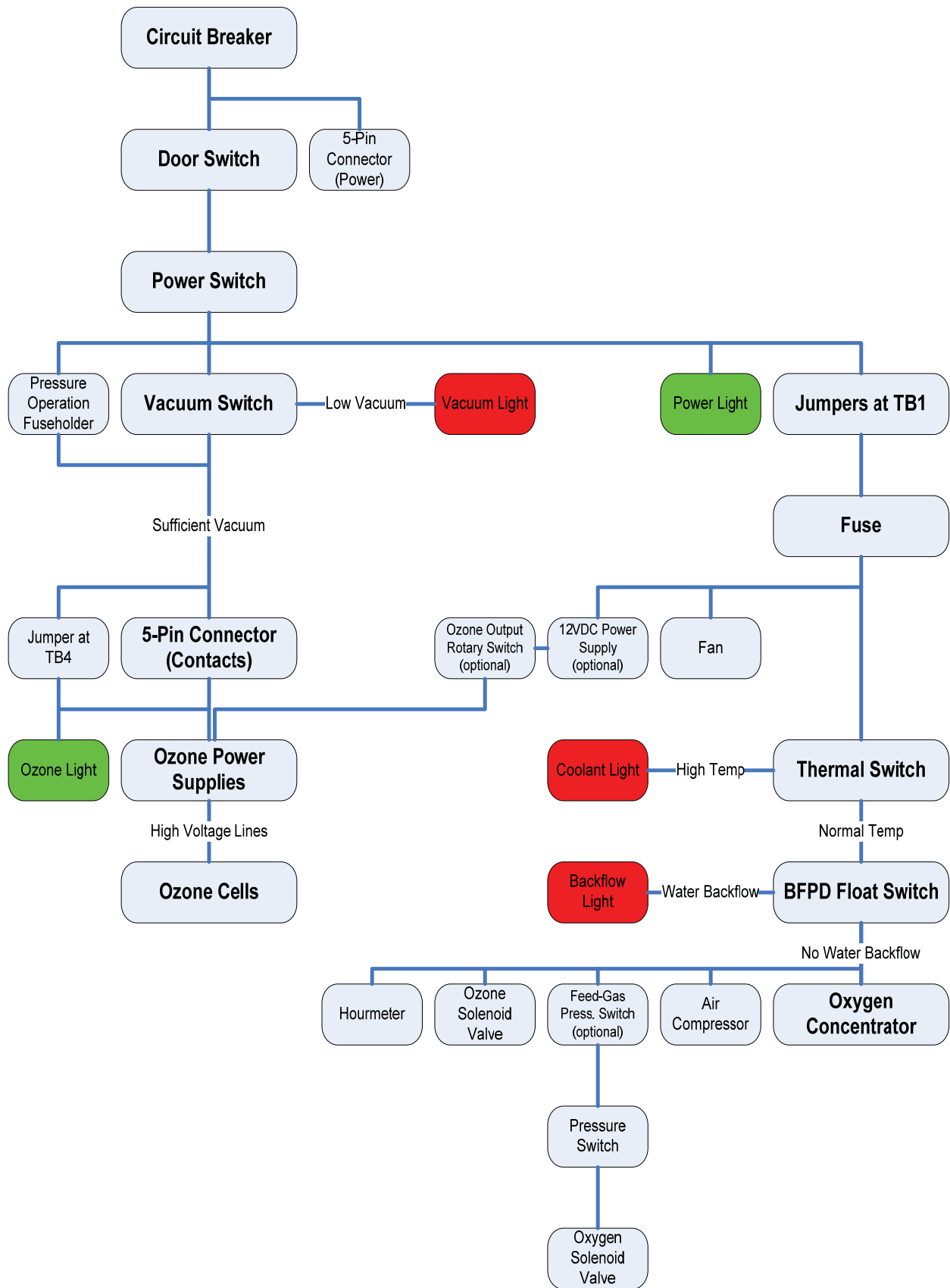

Pneumatic Component Order Diagram

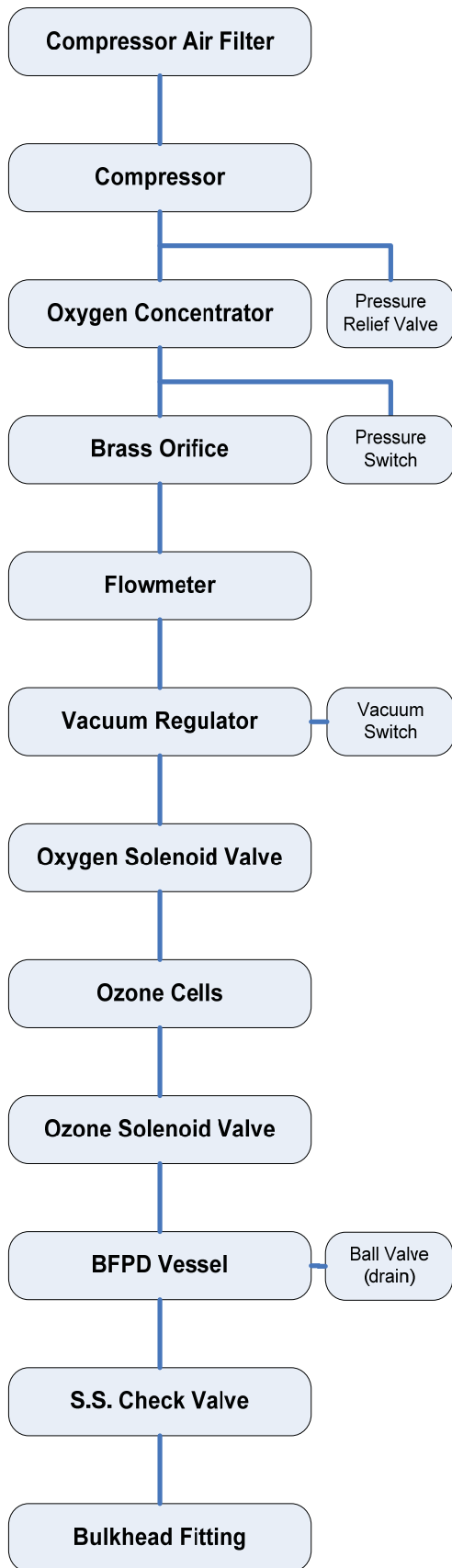

Hydraulic Component Order Diagram

