

GENESIS™

advanced cell technology

CD-45GV ALL MODELS Installation & Operations Manual



TABLE OF CONTENTS

SECTION 1 General Information

1A. Description	1
1B. Specifications	1

SECTION 2 Installation

2A. Location	1
2B. Mounting	1
2C. Electrical	2
2D. Plumbing	2

SECTION 3 Operation

3A. Initial System Start-Up	3
3B. Normal Operation	3
3C. System Shut-Down	3

SECTION 4 Maintenance & Service

4A. System Electro-Mechanical Overview	3
4B. PM Schedule	4
4C. Troubleshooting	7
4D. Contact Information	8

SECTION 5 Replacement Parts & Order Info

5A. Ordering Information	8
--------------------------------	---

Warranty	9
----------------	---

Appendix

Appendix "A" (Safety)	10
-----------------------------	----



**ALL Genesis™ CD Ozone
Generators are NSF listed.**

IMPORTANT SAFETY INSTRUCTIONS

READ AND FOLLOW ALL INSTRUCTIONS.

- Read this manual completely before attempting installation.
- Risk of Electric Shock. Install the ozone unit and any metallic plumbing associated with the unit at least 5 ft from the inside wall of tub or pool.
- Risk of Electric Shock. Connect this ozone generator in accordance with the installation instructions. Do not install within an enclosure that would restrict ventilation.
- Follow all applicable electrical codes.
- Electric shock hazard. Be sure to turn power OFF at power source before any service work is performed. Failure to do so could result in serious injury or death.
- Warning – Short term inhalation of high concentrations of ozone and long term inhalation of low concentrations of ozone can cause serious harmful physiological effects. DO NOT inhale ozone gas produced by this device.
- For your safety, do not store or use gasoline, chemicals or other flammable liquids or vapors near this or any other appliance.
- A spontaneous and violent ignition may occur if oil, grease or greasy substances come in contact with oxygen under pressure. These substances must be kept away from oxygen regulators, cylinder valves tubing and connections, and all other oxygen equipment.

SAVE THESE INSTRUCTIONS!

SECTION 1 General Information

1A. Description

The Genesis™ Corona Discharge series ozone generator described in this manual is designed to provide the benefits of ozonated water in an environmentally safe and effective manner. The high quality, specially engineered components ensure efficient ozone output and reliable performance.

The Genesis™ CD ozone generator is safe and harmless to your equipment if installed properly.

1B. Specifications

For detailed specifications refer to the ozone generator specification label located on the inside of the door on the unit.

Ozone Output:

Ozone output (+10%):	45 g/hr
Flow rate (max):	30 scfh
% weight O ₃ :	4.0

Power Requirements:

Domestic:	120 VAC 60Hz
Export:	230 VAC 50Hz
Overcurrent Protection:	20 A

Cooling Water Requirements:

0.2 GPM (.4 lpm) of clean, filtered, fresh water.

NOTE: Typical pool water may be used for cooling. Generator efficiency and life will be improved at inlet temperatures of 80°F or less.

Inlet temperature:	50°F - 90°F (10°C - 32°C)
Inlet pressure:	15.0 - 40 psi (100 - 270 kPa)

Location Requirements*:

Mounting: Floor or wall mount in a clean, protected area using supplied brackets.

Ambient Temp.: 40°F - 100°F (5°C - 38°C)

* Protection from weather elements must be provided for outdoor installations. Operating outside of the recommended temp. ranges may result in damage not covered under the manufacturer's warranty.

SECTION 2 Installation

2A. Location

CD-45G is designed for either floor or wall mounting in a clean, protected area, either indoors or outdoors. Locate generator out of reach of sprinklers or drainage spouts. Allow sufficient access for maintenance and all tubing and electrical wires. Generators must not be placed in locations where ambient ozone levels exceed 0.01 PPM.

2B. Mounting

NOTE: Do not remove compressor packing material until unit has been mounted.

2B-1. Wall Mount Option

1. Attach two mounting brackets to wall using anchors appropriate for mounting surface.

See Figure 1.

Note: Mount so that bottom of enclosure is at least 4" above the ground.

2. Using 1/4"-20 bolts (with washers as shown) secure generator to mounts.

2B-2. Floor Mount Option

1. Use the four 1/4"-20 bolts with washers to secure feet to bottom of cabinet.
2. Stand upright and securely fasten to concrete slab using appropriate anchors and bolts.

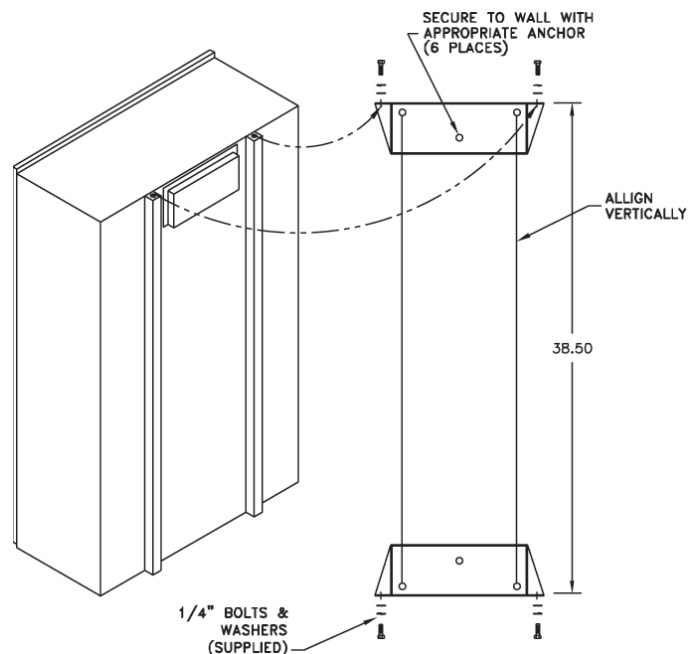

Figure 1: Wall Mount

2C. Electrical

Refer to the units specification label and local electrical codes for information on proper electrical connection.

Main power circuit: Unit is supplied with a 1/2" conduit elbow. Wire unit to a dedicated Breaker (30 AMP) installed in accordance with electrical codes.

2D. Plumbing

Ozone gas is introduced to the circulation line using a venturi injector. Suction developed by the venturi allows the CD to operate safely under vacuum. See installation manual for MX-601-XX for proper venturi installation.

2D-1. Ozone Gas Line

1. Connect ozone tubing to generator outlet fitting. (3/8" stainless steel compression fitting.)
2. Connect opposite end of ozone tubing to injector suction port. (Suction port fitting: 3/8" stainless steel compression fitting.) **See Figure 2.**

NOTE: The ozone gas supply line must be made of Teflon or stainless steel and have a back flow prevention device (such as a check valve) installed between the ozone generator cabinet and the point of injection to prevent water from backing up into the generator system. An ozone supply check valve is included with the MX-601-XX system.

2D-2. Cooling Water

Cooling water must be supplied as specified in Section 1B.

1/4" FPT connections are supplied on the generator. **See Figure 2.** Be sure that the tubing is appropriately matched with the marked inlet and outlet ports. Carefully match and connect to water plumbing as shown in Figure 2. Alternate method using connections at injector may be used.

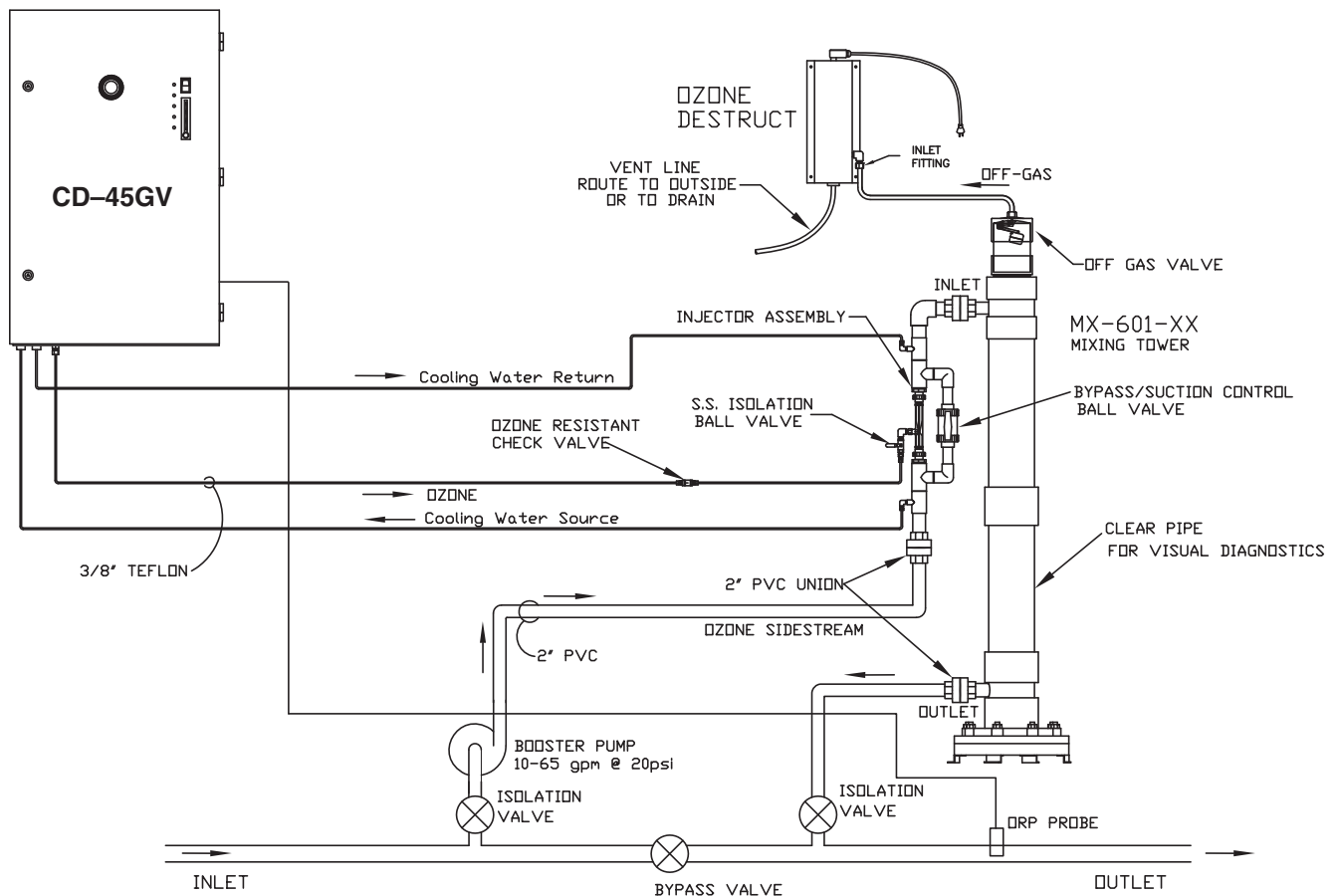

Figure 2: Plumbing Schematic - Example of Swimming Pool Application

SECTION 3 Operation

3A. Initial System Start-Up

Upon completing all of the generator system connections, you are ready to begin start-up procedures.

1. Check electrical fittings.
2. Check for proper voltage.
3. Turn on circulation pump.
4. Check for leaks.
5. Check cooling water.
6. Turn main power switch to "ON" position.
7. Adjust injector by-pass to attain required vacuum. (Green "Vacuum" light will go on.)

NOTE: Do not jog or immediately restart the system. Compressors require approximately 5 seconds to decompress.

3B. Normal Operation

With the power switch "ON", the system's compressors and cooling fans will start up, the oxygen concentrator will begin operating, and the output solenoid valve will open. Move the Ozone Output switch from "OFF." Approximately 1 minute after proper vacuum is attained, the last indicator ("Ozone Power") will turn on. The ozone generator will be producing ozone and injecting it into the process line.

All (6) indicator lights should be lit, and flow meter should indicate gas flow. If the optional ORP Controller is installed, it should be displaying a reading from the sensor probe and will automatically cycle the generator on and off as needed to maintain water quality. Residual ORP levels will vary per application.

However, the system will not start under any of the following conditions:

1. The system will not start-up if the door is not secured. A door interlock switch is incorporated into the system enclosure.
2. If the optional ORP controller is installed the ozone will not turn on if the ORP level is already above the setpoint of the ORP controller.
3. The ozone will not turn on if there is not enough vacuum being generated by water flow through injector. Green "Vacuum/Pressure" light will go on when proper vacuum is attained.
4. Ozone will not turn on if there is too much vacuum. Green "Vacuum/Pressure" light will go on when proper vacuum is attained.

If you experience complications, see TROUBLESHOOTING Section 4C or call 800-676-1335 for assistance.

3C. System Shut-Down

The Genesis™ Corona Discharge ozone generator is a specialized water cooled device that must be properly protected during shut-down/storage periods. The following sequence of steps must be used for servicing or for storage.

1. Toggle the main system power switch to the "OFF" position to shut-down generator.
2. After the generator has been shut-down, the process water circulation pump may be turned off.
3. If the system is going to be shut-down and stored during freezing weather, it is very important that the cooling water be drained to protect it from rupture or damage.

NOTE: Process water flow must not be shut-down when the ozone generator is operating. Doing so may cause water to backflow into the system and damage the generator cells.

SECTION 4 Maintenance & Service

4A. System Electro-Mechanical Overview

Refer to Figure 4 for component locations.

4A-1. Indicator Lights

1. **Main Power:** Indicates that power is being supplied to the ozone generator.
2. **Auxiliary Switch:** Indicates condition of flow switch and/or ambient ozone monitor.
3. **Water Backflow Detected:** Indicates system is free from water backflow into generator.
4. **Temperature:** Indicates that cooling water, ambient air, and compressor air temperatures are OK.
5. **Vacuum/Pressure:** Indicates proper gas system operation. Light will go out for either low or high vacuum conditions, or low pressure.
6. **Ozone Power:** Indicates that power is being supplied to the high voltage Corona Discharge circuits and that ozone is being produced.

4A-2. Remaining External Components

1. **Main Power Switch:** Power switch is used for system start-up and shut-down. Switch activates the control system allowing the generator to start-up.

2. **Flowmeter:** Flowmeter indicates the oxygen flow through the system.
 3. **Circuit Breaker:** Circuit breaker protects the generator from over current conditions. Push the breaker button to reset.
 4. **ORP Controller (optional):** ORP controller receives a millivolt (mV) signal from the ORP sensor mounted in the process water line. ORP (Oxidation-Reduction Potential) is a measure of the relative oxidation strength of the water. As ozone is added to the water system the ORP level will rise. As ozone is used up in the water system the ORP level will drop. The ORP controller continuously analyzes the sensor signal, compares it to the setpoint that has been programmed, indicates the ORP level on the digital display, and relays the signal to the ozone generator.
 5. **Ozone Output Switch:** Controls ozone output concentration by adjusting the number of power supplies operating.
 6. **Dissolved Ozone Monitor (optional):** Monitoring system designed for the continuous measurement of ozone gas in solution. The operating range of the system may be selected by the user from 0-2.00 PPM or from 0-20.00 PPM. The basic sensing element used is polarographic membraned sensor which measures ozone directly.
- 4A-3. Internal Components**
1. **Ozone Cell Assembly:** Cells are made of two aluminum halves. Enclosed in the aluminum halves are a ceramic tube, coil type high voltage electrode and a teflon rod.
 2. **High Voltage Supply(s):** Power supplies raise incoming line voltage and frequency to deliver it to the cells. Each power supply is rated at 100W.
 3. **Air Compressors:** Compressors produce and supply compressed air to oxygen concentrator.
 4. **Oxygen Concentrator:** Supplies concentrated, dry, oxygen feed gas to the ozone generator.
 5. **Vacuum Switches:** Interrupt system if system vacuum is too low (less than 1.5 inHg) or too high (greater than 7 inHg).
 6. **Vacuum Regulator:** Regulates the oxygen flow into the generator cell based on a vacuum setpoint (factory set to 3-5 in. Hg). When the sufficient suction is being developed by the injectors downstream the regulator will allow full flow to pass. As suction is reduced, flow is restricted proportionally to maintain the vacuum set point. If suction is lost completely, flow is cut off.
 7. **Water Backflow:** Backflow preventor senses water present in ozone tubing in generator. If water is detected, system will close solenoid valve to prevent additional water backflow from occurring. Water in the generator will cause severe damage to the high voltage electrodes.
 8. **Ventilation Fan:** Cooling fan operates when main power switch is "ON".
 9. **Air Filter:** Filter cleans ventilation air entering the enclosure.
 10. **Door Interlock Switch:** Interlock switch will shut down entire system if door is opened. Securing the door will bring the system back into operation.
 11. **Relay Panel:** Contains control relays for system interlocks, indicator lights and main power control.
 12. **Hour Meter:** Indicates total system operating time in hours.
 13. **Pressure Switch:** Interrupts system if pressure from compressors falls below 25 psig.
 14. **Temperature Switches:** Interrupt system if Ozone Cell Cooling Plate, Compressor Air, or Enclosure Intake Air Temperatures exceed maximum limits.
 15. **Compressor Filters:** Remove particles from compressor intake air. Top of canister is removed to access replaceable element (See Section 5B for part number).
 16. **Moisture Separator:** Filters and removes moisture from compressed air. Remove bowl to access replaceable element (See Section 5B for part number).

4B. Preventative Maintenance Schedule

Regular maintenance should be performed to avoid damage to the system, more costly repairs and to keep the warranty active. For instance, the compressor should be rebuilt every 8,750 hours to prevent the reduction in air-pressure and flow. If the compressor is not rebuilt, oxygen concentrator sieve beds will become plugged and unusable, creating more costly problems. If the generator cells are not cleaned or replaced annually, a lower ozone output will result.

DAILY:

- Check ozone generator for proper operation.
- Make sure all appropriate green indicator lights are lit.
 - Make sure flow meter is indicating proper air flow.

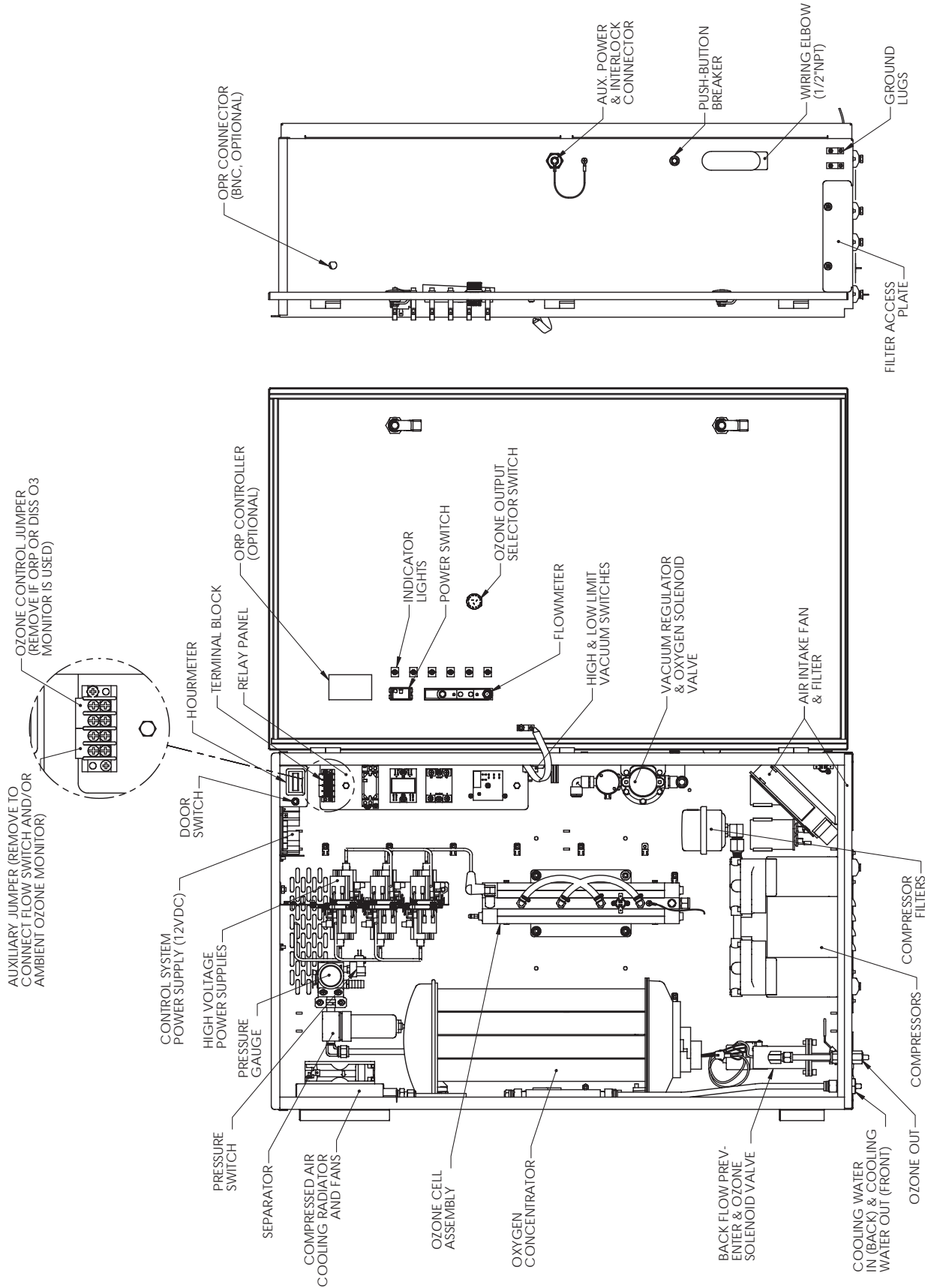

Figure 3: Component Locations (ALL MODELS EXCEPT -50)

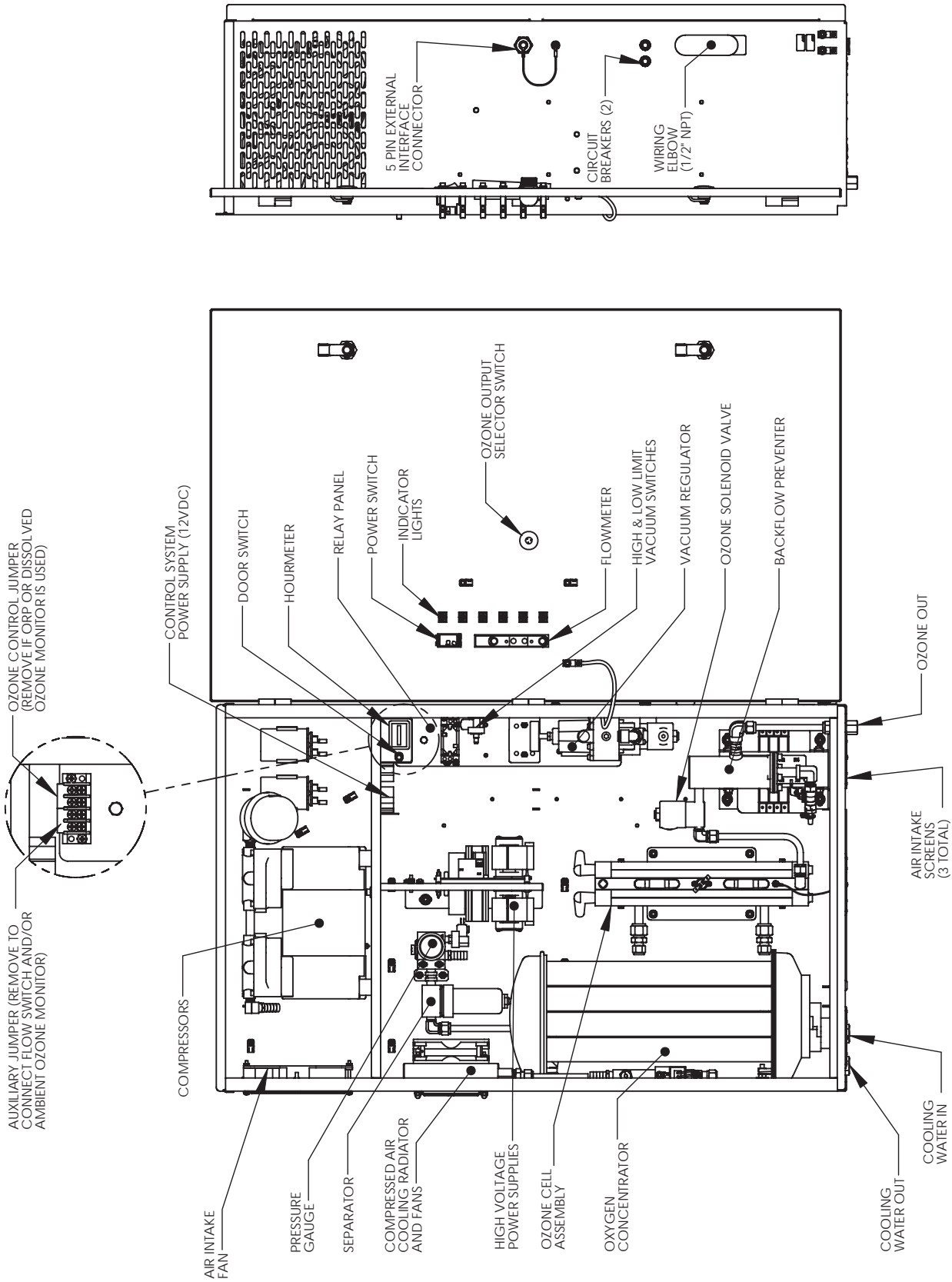

Figure 4: Component Locations (-50 MODELS)

MONTHLY:

1. Inspect compressor air filter.
 - Replace quarterly
2. Remove and clean air filter or intake screens

See Figure 5.

 - Remove filter cover plate to access filter.
 - Rinse filter in warm, soapy water and blow dry.
 - Reinstall filter.
3. Perform general cleaning of cabinet interior.
4. Clean separator, replace filter as necessary.

EVERY 8,750 HOURS:

1. Rebuild compressor. Kit Available. See Section 5 for ordering information.
2. Replace/Service Check Valve(s) and Solenoid Valves.
3. Replace ozone cell O-rings and inspect ozone cells.

4C. Troubleshooting

Knowledge of electrical applications is required for troubleshooting. Contact a certified electrician if you are unsure of your ability to service the equipment. If any condition persists, call 800-676-1335 for technical assistance.

NOTE: Fault switches are wired in series. Whatever the fault mode, all indicators below the affected light will also be off.

Symptom: "Main power" light out when system switch is in the "ON" position.

1. No power to the generator:
 - a. Check the circuit breaker at the facility power distribution box.

- b. Check for loose connections or wiring breaks from the power distribution box to the generator.

2. G.F.C.I. has tripped.*

- a. Check power cord and reset G.F.C.I.

3. Circuit breaker has tripped.*

- a. Reset breaker.

* If G.F.C.I. or breaker continue to trip after reset, call for technical assistance.

Symptom: "Ozone power" indicator light out.

1. If optional ORP is installed, ORP may have shut-down the generator when ORP level reached setpoint.
 - a. Wait for ORP to come down. Generator will restart when ORP level is below set point.
2. Selector switch in "OFF" position.

Symptom: "Vacuum/Pressure" indicator light is off indicating out of range vacuum being supplied.

1. Injector not supplying adequate suction.
 - a. Check pump and ensure water is flowing through injector.
 - b. Check by-pass valve and adjust if necessary to obtain proper pressure differential in order to reestablish suction.
2. Injector supplying too much suction.
 - a. Check by-pass valve and adjust to obtain proper suction.
 - b. Check system back pressure and increase to reduce suction.
3. Compressors not supplying proper pressure.
 - a. Check compressor filters.

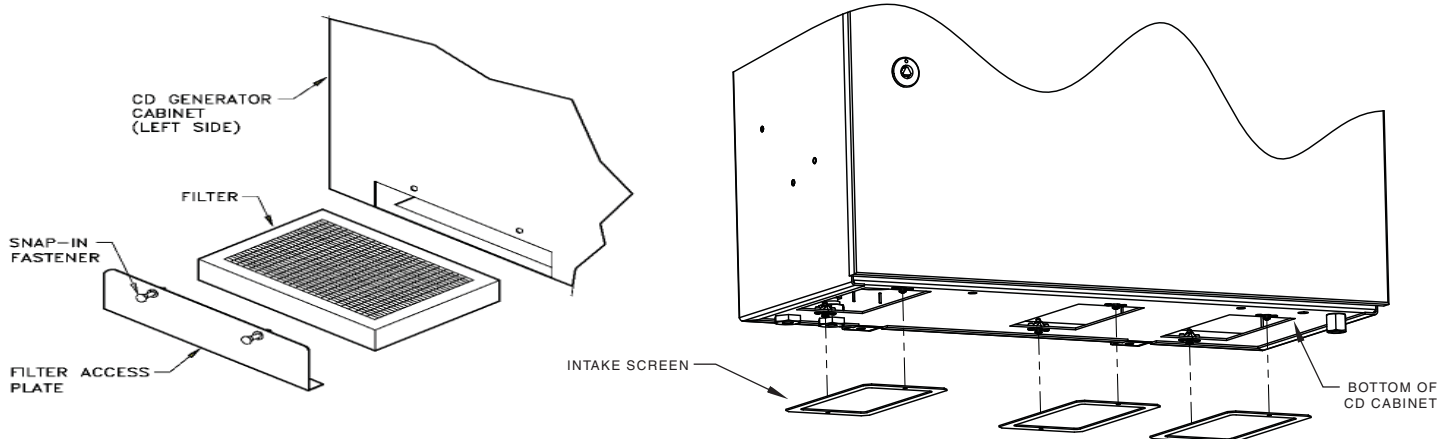

Figure 5: Filter or Intake Screen Removal for Cleaning

Symptom: "Temperature" indicator light is off.

1. Coolant water flow has been interrupted.
 - a. Check all tubing connections, ensuring tight, leak free connections.
 - b. Trace tubing and look for blockage of flow.
 - c. Re-establish proper coolant water flow.
2. Air into the cabinet is too hot.
3. Compressor air is too hot, check radiator fans.

Symptom: "Water backflow" indicator light is off.

1. Water has backed into generator from injector.
 - a. Establish proper water flow through injector and correct suction.
 - b. Drain Back Flow Preventer by opening cabinet and opening 1/4" stainless steel ball valve.
 - c. After water has completely drained close drain valve, secure cabinet door and restart system.

Symptom: CD Module is not operating. Ozone output has dropped.

1. No power to the generator module from the power supply:
 - a. Check H.V. cables for breaks or loose connections, replace if necessary.
 - b. Check for power at input terminals of the H.V. transformers.*
 - c. Check ozone power relay for loose connections or faulty operation.

* **CAUTION: HIGH VOLTAGE.**

Symptom: No air flow through the generator. The air flow meter indicates 0 scfh flow.

1. Air compressor is not operating properly.
 - a. Listen for air compressor operation.
 - b. Check all tubing connections from the air compressor through the system for leaks.
 - c. Check filters.

4D. Contact Information

For Technical assistance:

Call: 1-800-676-1335 ext. 293

Email: service@delozone.com

Visit: www.delozone.com

SECTION 5 Replacement Parts & Order Information

5A. Ordering information

For replacement parts call DEL at 1-800-676-1335.

Be prepared with the following information:

- Customer Name
- Customer Address
- DEL Model Number
- DEL Serial Number
- Date Purchased
- Proof of Purchase

DEL OZONE COMMERCIAL PRODUCT LIMITED TWO YEAR WARRANTY

The limited warranty set forth below applies to products manufactured by DEL OZONE – 3580 Sueldo Street, San Luis Obispo, California 93401, and sold by DEL OZONE or its authorized dealers. This limited warranty is given only to the first retail purchaser of such products and is not transferable to any subsequent owners or purchasers of such products. Systems sized 65 grams or greater require factory commissioning and startup to maintain warranty as set forth below.

DEL OZONE warrants that DEL or DEL authorized dealers will repair or replace, at DEL's option, any part of such products proven to be defective in materials or workmanship within two (2) years of the date of receipt. Parts are covered under the two (2) year warranty when and only when the stated maintenance requirements are met. Contact tanks and degas valves have a ninety (90) day warranty. Compressor(s) must be maintained per operation and maintenance manual. Required maintenance includes a compressor rebuild after one (1) year or every 8,760 hours, which ever is reached first. Warranty does not include parts for compressor(s) rebuild kit(s), or other consumable items. See owner's manual for complete maintenance details. This Warranty specifically excludes any components not manufactured by DEL OZONE that are external to the products covered, such as pumps, air compressors, monitors, tanks, or related components. DEL OZONE will assist with warranty claims for such components purchased through DEL OZONE; limited to the extent of the manufacturer's standard warranty. **ANY REPAIR OR REPLACEMENT WILL BE WARRANTED ONLY FOR THE BALANCE OF THE ORIGINAL TWO (2) YEAR WARRANTY PERIOD**

NOTE: USE ONLY DEL AUTHORIZED DEL REPLACEMENT PARTS. USE OF ANY OTHER PART(S) WILL VOID THIS WARRANTY.

Any replaced parts must be returned to DEL OZONE for warranty evaluation.

THIS LIMITED WARRANTY DOES NOT INCLUDE ANY OF THE FOLLOWING:

- (a) Any labor charges for troubleshooting, removal, or installation of such parts.
- (b) Any repair or replacement of such parts necessitated by faulty installation, improper maintenance, improper operation, misuse, abuse, negligence, accident, fire, flood, repair materials, and/or unauthorized accessories.
- (c) Any such products installed without regard to required local codes and accepted trade practices.
- (d) Damage to unit caused by water backflow;
- (e) Any implied warranty of merchantability or implied warranty of fitness for particular purpose, and such warranties are hereby disclaimed.
- (f) DEL Ozone shall not be liable under any circumstances for loss of use of such product, loss of profits, direct damages, indirect damages, consequential damages, and / or incidental damages.

This warranty gives you specific legal rights. You may have other rights which vary from state to state.

Extended Warranties and Service Agreements are available. Contact DEL for additional details.

TO OBTAIN WARRANTY SERVICE:

DEL OZONE
3580 Sueldo, San Luis Obispo, CA 93401
Customer Service Number: (800) 676-1335
Fax Number: (805) 541-8459
E mail: service@delozone.com

PROVIDE:

- 1. Project, contact name, mailing address and telephone.**
- 2. Installer/Mechanical Contractor.**
- 3. Unit Part Number, Serial Number, and date of purchase.**
- 4. The date of failure.**
- 5. A description of the failure.**

After this information is provided, DEL Ozone may release a *RETURN GOODS AUTHORIZATION (RGA) NUMBER*. After receiving the RGA number the part in question must be returned to DEL Ozone, freight prepaid, with the RGA number clearly marked on the outside of the package. All preauthorized defective parts must be returned to DEL Ozone within thirty (30) days. Under no circumstances may any product be returned to DEL Ozone without prior authorization. Returns without the assigned RGA number on the outside of the package will be refused and shipped back to the sender at their expense. Upon receipt of preauthorized returned goods, DEL Ozone will repair or replace, at DEL Ozone's option, the defective product(s) and return them (freight prepaid for products under warranty). Buyer's acceptance of the product and use thereof constitutes acceptance of these terms.

APPENDIX “A” SAFETY

OZONE

Material Safety Data Sheet

SECTION I: MATERIAL IDENTIFICATION							
IDENTITY: OZONE (Gaseous)	ISSUED: February, 1992						
FORMULA: O ₃	REVISED: March, 2009						
<p>Description (origin/uses): Occurs in atmosphere from UV light action on oxygen at high altitude. Commercially obtained by passing air between electrodes carrying a high voltage alternating current. Also found as a by-product in welding areas, high voltage equipment, or UV radiation.</p> <p>Ozone is used as an oxidizing agent in air and water disinfection: for bleaching textiles, oils, and waxes; organic synthesis as in processing certain perfumes, vanillin, camphor; for mold and bacteria control in cold storage.</p>							
<p>Cautions: A powerful oxidizing agent, ozone generally exists as a gas and is highly chemically reactive. Inhalation produces various degrees of respiratory effects from irritation to pulmonary edema (fluid in lungs) as well as affecting the eyes, blood, and central nervous system.</p>							
<p>Manufacturer/Supplier: On-site generation, equipment available from various suppliers, including:</p> <table style="width: 100%; border: none;"> <tr> <td style="width: 50%;">DEL Ozone</td> <td style="width: 50%;">Phone: (805) 541-1601</td> </tr> <tr> <td>3580 Sueldo Street</td> <td>FAX: (805) 541-8459</td> </tr> <tr> <td>San Luis Obispo, CA 93401</td> <td></td> </tr> </table>		DEL Ozone	Phone: (805) 541-1601	3580 Sueldo Street	FAX: (805) 541-8459	San Luis Obispo, CA 93401	
DEL Ozone	Phone: (805) 541-1601						
3580 Sueldo Street	FAX: (805) 541-8459						
San Luis Obispo, CA 93401							
SECTION II: INGREDIENTS AND HAZARDS							
Ozone, CAS No. 10028-15-6: NIOSH RTECS No. RS8225000							
1991 OSHA PELs 8-hr TWA: 0.1 ppm vol. (0.2 mg/m ³) 15-min STEL: 0.3 ppm vol (0.6 mg/m ³)	1991-1992 ACGIH TLV Ceiling: 0.1 ppm (0.2 mg/m ³)						
1990 IDLH 10 ppm	1990 DFG (Germany) MAK TWA: 0.1 ppm (0.2 mg/m ³)						
1990 NIOSH REL Ceiling: 0.1 ppm vol. (0.2 mg/m ³)	Category 1: Local Irritant Peak Exposure Limit: 0.2 ppm 5 min momentary value, 8 per shift						
Other Designations: Triatomic oxygen: CAS No. 10028-15-6, NIOSH RTECS No. RS8225000							
SECTION III: PHYSICAL DATA							
Boiling Point: -169° F	Melting Point: -315.4° F (-193° C)						
Vapor Pressure: >1 ATM	% Volatile by Volume: 100%						
Vapor Density (AIR = 1): 1.6	Molecular Weight: 48 Grams/Mole						
Solubility in Water: 0.49 ml @ 32° F (0° C), 3 ppm @ 20° C	pH: Not Listed						
	Critical Temperature: 10.22° F (-12.1° C)						
<p>Appearance and Odor: Colorless to blue gas (greater than -169° F): characteristic odor often associated with electrical sparks or lightning in concentrations of less than 2 ppm and becomes disagreeable above 1-2 ppm. CAUTION: Olfactory fatigue develops rapidly, so do not use odor as a preventative warning device.</p>							
SECTION IV: FIRE AND EXPLOSION HAZARD DATA							
Flash Point: Nonflammable							
Extinguishing Media:	Use large amounts of water spray or fog to put out fires involving ozone. Use appropriate fire-fighting techniques to deal with surrounding material.						
<p>Special Fire Fighting Procedures: Wear a self contained breathing apparatus with full face pieces operated in a pressure-demand or other positive-pressure mode.</p>							
<p>Unusual Fire/Explosion Hazards: Decomposition of ozone into oxygen gas, (O₂), can increase strength of fire.</p>							
SECTION V: REACTIVITY DATA							
<p>Stability: Ozone is not stable. Hazardous polymerization cannot occur.</p>							
<p>Chemical Incompatibilities: Ozone is chemically incompatible with all oxidizable materials, both organic and inorganic.</p>							
<p>Conditions to Avoid: Ozone is unstable at room temperatures and spontaneously decomposes to oxygen gas. Avoid ignition sources such as heat, sparks, and open flame. Keep away from strong reducing agents and combustible materials such as grease, oils, and fats.</p>							
<p>Products of Hazardous Decomposition: Ozone spontaneously decomposes to oxygen gas, even at room temperatures.</p>							

4-0697_ Rev.B

SECTION VI: HEALTH HAZARD DATA

Carcinogenicity: Ozone is not listed as a carcinogen by the NTP, IARC, or OSHA.

Primary Entry: Inhalation

Target Organs: Respiratory system, eyes, blood.

Summary of Risks: There is no true threshold limit and so no exposure (regardless of how small) is theoretically without effect from ozone's strong oxidative ability. Ozone passes straight to the smallest bronchioles and alveoli and is not absorbed by mucous membranes along the way. Initial small exposure may reduce cell sensitivity and/or increase mucous thickness producing a resistance to low ozone levels. Short exposure to 1-2 ppm concentrations causes headache as well as irritation to the respiratory tract. but symptoms subside when exposure ends. High concentrations of ozone produce severe irritation of the eyes and respiratory tract. Exposure above the ACGIH/OSHA limits produce nausea, chest pain, coughing, fatigue, reduced visual acuity, and pulmonary edema. Symptoms of edema from excessive exposure can be delayed one or more hours. Inhalation of >20 ppm for an hour or more (>50 ppm for 1/2 hour) can be fatal.

Acute Effects: Acute damage from ozone appears to be mainly from its oxidizing effect on contact with tissue.

Chronic Effects: Respiratory disease. Deleterious effects on lungs and acceleration of tumors have been reported.

Medical Conditions Generally Aggravated by Long-Term Exposure: History of respiratory or heart disorders.

First Aid: Remove from ozone containing air, get prompt medical help*, administer oxygen if necessary.

Eye Contact - Gently lift eyelids and flush eyes continuously with flooding amounts of water for 15 minutes or until transported to a medical facility*.

Inhalation - Remove exposed person to fresh air, support breathing, administer humidified oxygen as needed, get medical help*.

Ingestion - Highly unlikely since ozone is a gas until -169° F,

* **GET MEDICAL ASSISTANCE = APPROPRIATE IN-PLANT, PARAMEDIC, or COMMUNITY.** Get prompt medical assistance for further treatment, observation, and support after first aid.

SECTION VII: PRECAUTIONS FOR SAFE HANDLING AND USE**Steps to be Taken in Case of Spill/Leak:**

1. Discontinue production
2. Isolate and vent area
3. Immediately notify personnel
4. Deny entry
5. Follow applicable OSHA regulations

Disposal: Provide ventilation to dilute and disperse small amounts of ozone (below OSHA PELs) to outside atmosphere. Follow federal, state, and local regulations.

Handling/Storage Precautions: Ensure proper personnel training and establish emergency procedures.

SECTION VIII: CONTROL MEASURES

Respiratory Protection: High Level (>10 ppm) - Self Contained Breathing Apparatus: MISH/NIOSH approved.
Low Level (0.3 - 10 ppm) - Canister Type (carbon) respirator may be used.

Eye Protection: Wear chemical safety goggles if necessary to work in high ozone (>10 ppm).

Skin Protection: Effects of ozone on skin are minimal to non-existent.

Ventilation: Provide general and local exhaust ventilation to dilute & disperse small amounts of ozone into outside atmosphere.

SECTION IX: SPECIAL PRECAUTIONS AND COMMENTS

Storage Segregation: Prevent ozone from coming into direct physical contact with strong acids or bases or with strong oxidizing/reducing agents.

Engineering Controls: Install ventilation systems capable of maintaining ozone to concentrations below the ACGIH/OSHA exposure limits (see sect. II). Install ambient ozone monitor(s) configured to shut down ozone equipment and turn high speed ventilation on.

Material Safety Data Sheet

This MSDS complies with OSHA's Hazardous Communication Standard 29 CFR 1910.1200 and OSHA form 174.

DEL Ozone
3580 Sueldo Street
San Luis Obispo, CA 93401
 Product Information 805-541-1601

NFPA 704 Designation Hazard Rating

4 = Extreme
 3 = High
 2 = Moderate
 1 = Slight
 0 = Insignificant

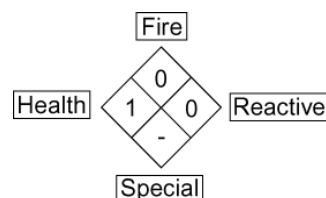

Product Name		AQUEOUS OZONE SOLUTION			
Chemical Name		DISSOLVED OZONE GAS IN WATER 0 TO 2 PPM			
Product Description		AQUEOUS SOLUTION OF OZONE DISSOLVED IN POTABLE WATER			
D.O.T. Shipping Classification		NON REGULATED			
I PHYSICAL DATA					
Boiling Point	212 F	Freezing Point	32 F		
Specific Gravity	1.0	Solubility in Water	COMPLETE		
Evaporation Rate	APPROX 1	Physical Form	LIQUID		
Appearance & Odor	COLORLESS (CLEAR) WATER WITH FRESH, ASEPTIC ODOR				
II HAZARDOUS INGREDIENTS					
MATERIAL	HAZARD	CAS #	% BY WT	ACGIH TLV	OSHA PEL
None					
III FIRE AND EXPLOSION HAZARD DATA					
Flash Point	NA	Method	NA	Auto Ign. Temp.	NA
Flammable Limits in Air	NON APPLICABLE		Lower	NA	Upper NA
Extinguishing Media	NON APPLICABLE				
Unusual Fire & Explosion Hazards	NONE				
Special Fire Fighting Procedures	NONE				

Material Safety Data Sheet Cont.Product Name **AQUEOUS OZONE SOLUTION**

IV HEALTH HAZARD DATA	
Threshold Limit Value	NOT DETERMINED
Route of Exposure	<input type="checkbox"/> Inhalation <input type="checkbox"/> Ingestion <input type="checkbox"/> Skin <input checked="" type="checkbox"/> Eye <input checked="" type="checkbox"/> Not Hazardous
Eye Contact Hazard	Exposure may cause mild eye irritation, but is not expected.
Ingestion Hazard	Not Hazardous
Inhalation Hazard	Inhalation is not likely to be a primary route of exposure but could become irritating if aerosols are exposed to individual for extended period of time.
Skin Contact Hazard	No skin irritation is expected from short term exposure.
Skin Absorption Hazard	No published data indicates this product is absorbed through the skin.
Effects of Acute Exposure	Mild skin or eye irritation.
Effects of Chronic Exposure	Repeated exposure of the skin to concentrated product should be avoided to prevent irritation and drying of the skin.
V EMERGENCY AND FIRST AID PROCEDURES	
Eye Contact	If exposure to water containing aqueous solution of ozone causes irritation to eyes, flush eyes with plenty of clean, ozone free, running water for at least 15 minutes, lifting the upper and lower lids occasionally. Remove contact lenses if worn. Seek medical attention if irritation persists.
Skin Contact	Not likely to become irritated unless repeatedly exposed to large volumes of material. If irritation develops, rinse affected area with ozone free potable water. If irritation continues seek medical advice.
Inhalation	Inhalation of mists could lead to irritation of lungs. If symptoms develop, move individual away from exposure and into fresh air. If symptoms persist, seek medical attention.
Ingestion	NA
VI REACTIVITY DATA	
Incompatibility (Materials to Avoid)	Natural rubber (may degrade, or "dry", rubber components over extended periods of exposure)
Conditions to Avoid	NONE KNOWN
Hazardous Decomposition	NONE
Stability	<input checked="" type="checkbox"/> STABLE <input type="checkbox"/> UNSTABLE Hazardous Polymerization <input type="checkbox"/> MAY OCCUR <input checked="" type="checkbox"/> WILL NOT OCCUR

Material Safety Data Sheet Cont.Product Name **AQUEOUS OZONE SOLUTION**

VII SPILL OR LEAK PROCEDURES				
Steps To Be Taken If Material Is Released Or Spilled		NONE		
Waste Disposal Method		DISPOSE OF THE SAME AS POTABLE RINSE WATER		
VIII SPECIAL PROTECTIVE INFORMATION				
Respiratory Protection (Specify Type)		NOT REQUIRED FOR NORMAL USE OF THIS PRODUCT		
Ventilation	Local Exhaust	PREFERABLE	Special	NA
	Mechanical (general)	OK	Other	NA
Protective Gloves	NOT REQUIRED			
Eye Protection	NOT REQUIRED			
Other Protective Equipment	NOT REQUIRED			
IX SPECIAL PRECAUTIONS				
Precautionary Labeling	Certified testing of DEL Ozone systems by NSF (National Sanitation Foundation) has shown that under normal conditions of use, aqueous solutions containing low levels of ozone gas dissolved in potable water do not present a safety hazard when contact to the individual is incidental. When used in a room with normal ventilation, levels of ozone gas being released into the air have been shown by NSF to be well below the periodic exposure levels established by OSHA for worker safety through the use of DEL's ozone management technology.			
Precautions To Be Taken In Handling	Aqueous solutions of ozone in potable water should not be sprayed as an aerosol (i.e. >20psi) to avoid releasing higher levels of ozone gas into the work area. The decay rate of ozone gas is a function of temperature and exposure to organic material. Certified testing has shown that when ozone gas has been properly dissolved in ambient temperature (or colder (33 – 70 °F)) potable water at a level not exceeding 2 mg/l (ppm) using DEL's ozone management technology, the rate at which ozone is released from the water as ozone gas is below the PEL established for gaseous ozone.			
Rev. Date 03/26/09				
This material safety data sheet is provided as an information resource only. It should not be taken as a warranty or representation for which the preparer assumes legal responsibility. While we believe the information contained herein is accurate and compiled from sources believed to be reliable, it is the responsibility of the user to investigate and verify its validity. The buyer assumes all responsibility of using and handling the product in accordance with applicable federal, state, and local regulations.				



3580 Sueldo Street, San Luis Obispo, CA 93401 | 800.676.1335 | o3info@delozone.com | www.delozone.com
EPA Estab. No. 071472-CA-001