

AGW-0500

Mobile Ozone Surface Sanitation System

Installation & Operations Manual



DEL ozoneTM
advanced sanitation solutions

TABLE OF CONTENTS

SECTION 1 General Information

1A. Description 1
 1B. Specifications 1
 1C. Layout & Accessories..... 1

SECTION 2 Installation

2A. Location2
 2B. Electrical.....2
 2C. Plumbing2

SECTION 3 Operation

3A. Control Panel Overview2
 3B. System Start-Up3
 3C. System Shut-Down.....3
 3D. Standard Operating Procedures.....3

SECTION 4 Maintenance & Service

4A. Preventative Maintenance Schedule..... 6
 4B. Troubleshooting..... 6

SECTION 5 Replacement Parts & Order Info

5A. Ordering Information 7
 5B. Standard Replacement Parts List..... 7

SECTION 6 Ozone Overview & Safety Procedures

6A. Ozone Use & Technology Overview 7
 6B. General Safety Information..... 7
 6C. Hazards 8
 6D. Precautions for Safe Handling & Use 9
 6E. Monitoring..... 9
 6F. First Aid Procedures 10
 6G. MSDS..... 11

Warranty 12

Appendix

Appendix "A" (Daily Data Log)..... 14
 Appendix "B" (Emergency Information)..... 16
 Appendix "C" (Safety)..... 18



IMPORTANT SAFETY INSTRUCTIONS

READ AND FOLLOW ALL INSTRUCTIONS.

Read this manual completely before operation of AGW-0500 Ozone Generator Equipment. The High Voltage Transformers in this unit create 7,000 volts, with the outer jacket of the High Voltage lead reaching 3,000 volts.

- USE EXTREME CAUTION -

Operate the AGW-0500 on a near level surface with safe access to electrical power.

Connect to a G.F.C.I. type receptacle.

Follow all applicable electrical codes.

Do not bury cord.

WARNING: To reduce the risk of electrical shock, replace damaged cord immediately.

ELECTRICAL SHOCK HAZARD: Turn OFF all power switches and disconnect power cord from power source receptacle before performing any service work. Failure to do so could result in serious injury or death.

SAFETY CLAIMS

Performance safety testing was based on the **Hazard Communication Standard** as promulgated through the **Occupational Safety and Health Act** of 1970 and documented in the Code of Federal Regulations, Title 29, Chapter XVII, Part 1910, Section 1910.1200. The inherent low hazard due to the AGW-0500's design and construction, coupled with the safety features, monitoring data, and the precautionary directions provided in the owner's manual are sufficient for The Toxicology Group, LLC, a division of NSF International (Ann Arbor, MI), to provide a professional opinion that the AGW-0500 Mobile Ozone Surface Sanitation System poses no safety concerns when operated under the prescribed conditions as set forth in the owner's manual.

ANTIMICROBIAL CLAIMS

This device has been determined acceptable for use as an ozone generating device providing sanitization and disinfection of hard, inanimate, pre-cleaned surfaces, in and around food processing areas (P1). A potable water rinse is not required following the use of this device on previously cleaned hard surfaces.

NSF International Registration for this device is based, partially, upon documentation indicating that it meets all necessary requirements including labeling, EPA Establishment Registration, and safety requirements set forth under Federal Insecticide, Fungicide, and Rodenticide Act (FIFRA) of June 5, 1947, Section 2(q)(1) and Section 7.

Efficacy studies conducted according to AOAC Official Method 961.02; Germicidal Spray Products as Disinfectants Test and AOAC Official Method 960.09*; Germicidal and Detergent Sanitizing Action of Disinfectants provided the following results:

Organism	Applied Dose	Actual Dose (at nozzle)	Spray Duration	Reduction
Trichophyton mentagrophytes (ATCC 9533)	3.0 ppm	1.85-2.25 ppm	30 seconds	6 log (99.9999%)
Salmonella choleraesuis (ATCC 6538)	3.0 ppm	1.85-2.25 ppm	3 minutes	6 log (99.9999%)
Staphylococcus aureus (ATCC 6538)	3.0 ppm	1.85-2.25 ppm	10 minutes	6 log (99.9999%)
Pseudomonas aeruginosa (ATCC 15442)	3.0 ppm	1.85-2.25 ppm	5 minutes	6 log (99.9999%)
Campylobacter jejuni (ATCC 15442)	3.0 ppm	1.85-2.25 ppm	3 minutes	4 log (99.99%)
Listeria monocytogenes (ATCC 7644)	3.0 ppm	1.85-2.25 ppm	3 minutes	4 log (99.99%)
Aspergillus flavus (ATCC 9296)	3.0 ppm	1.85-2.25 ppm	5 minutes	4 log (99.99%)
Brettanomyces bruxellensis (ATCC 10560)	3.0 ppm	1.85-2.25 ppm	3 minutes	4 log (99.99%)
Escherichia coli* (ATCC 11229)	3.0 ppm	2.1 ppm	30 seconds	5 log (99.9999%)

SECTION 1 General Information

1A. Description

The AGW-0500 is a direct ozone spray system that makes 8 grams of ozone per hour. It provides approximately 9 GPM water flow with an applied ozone dose of 3-3.5 ppm in the water (average dissolved ozone concentration at the spray nozzle is 2.0 ppm with clean, potable water free of iron and manganese). **The AGW-0500 provides a final sanitizing rinse, leaving no residual.**

The AGW-0500 is designed to sanitize barrels and tanks; clean walls and floors; sanitize drains and hoses; conveyors, containers, wettable surfaces and equipment; and CIP equipment. Compatible materials include stainless steel, plastics, wood, concrete, cement, cement block, painted and unpainted. The AGW-0500 uses interchangeable attachments for spray applications and CIP fitting for CIP systems requiring flow of 9 GPM or less.

1B. Specifications

Ozone Output:

Ozone output ($\pm 10\%$):	8 g/hr
Applied Ozone Dose:	3-3.5 ppm
Gas flow rate (max):	7 scfh
% weight O ₃ :	3.0%

Power Requirements:

Domestic:	115VAC, 60 Hz, 1Ø, 18.0 A
International:	230VAC, 50 Hz, 1Ø, 12.0 A

Water Flow Rate (Approx): 9 GPM

NOTE: The purpose of the pump in the AGW-0500 is to provide the proper pressure and flow rate for the most efficient injector operation.

It is designed to operate with a specific flow-rate (9 GPM) and nozzle pressure (20 psi).

Accessories installed on the system must have these flow parameters or the system will not operate. Only DEL attachments may be used (See Figure 1, page 2). Please call DEL if further explanation is required.

Supply Water Requirements:

Temperature: 40°F - 80°F (greater than 90°F will damage the AGW-0500)

Pressure: 20-85 psi (greater than 85 psi will damage the AGW-0500)

Flow: 10 GPM (min.)

Ambient Temp.: 40°F - 90°F (not to exceed 90°F)

1C. Layout & Accessories

The AGW-0500 is a low pressure, ozone-enriched cold water surface sanitizer. Internally it is separated into two basic sections – dry and wet – as discussed below and shown in Figure 1, page 2.

Dry Section - Ozone Generation:

- Air Compressor:** Oilless, piston air compressor pumps ambient air at 2.5 cfm into the oxygen concentrator
- Oxygen Concentrator:** The oxygen concentrator uses a PSA (pressure swing absorption) molecular sieve to remove dirt, moisture, nitrogen and other trace gases, producing oxygen at greater than 85% purity and less than -60°C dewpoint. Concentrated oxygen feed-gas enables ozone generation at 2-6% (by weight) concentration.
- Ozone Generation Cell:** The corona discharge ozone generation cell consists of an aluminum housing (ground, two end housings, and fasteners), gaskets, high voltage stainless steel electrode, ceramic dielectric, oxygen inlet fitting, and ozone outlet fitting. Concentrated oxygen gas is pulled into the ozone generation cell under vacuum. The oxygen molecules are split into atomic oxygen which then recombine to form ozone gas.

Wet Section - Ozone Dissolution in Water:

- Water Pump:** 1 HP, SS, multistage. The pump operates at 9 GPM and creates a nozzle pressure of 20 psi, providing optimum performance parameters for the ozone injector for maximum ozone mass transfer into the water flow.
- Ozone Injector:** Inlet water flows through the pump and through the ozone injector, creating vacuum that pulls ozone gas from the ozone generation module and injects the ozone into the water flow. The injector is sized and factory preset to dissolve a minimum of 90% of the ozone gas into the water flow continuously.
- Ozone Degas Chamber:** Ozone-enriched water from the ozone injector flows into the degas chamber where the counter-current design forces any undissolved ozone gas through the float valve-protected top vent to the Ozone Destruct.
- Ozone Destruct:** Undissolved ozone gas passes through the heated catalytic ozone destruct which is made of non-consumable manganese dioxide (heat protected from

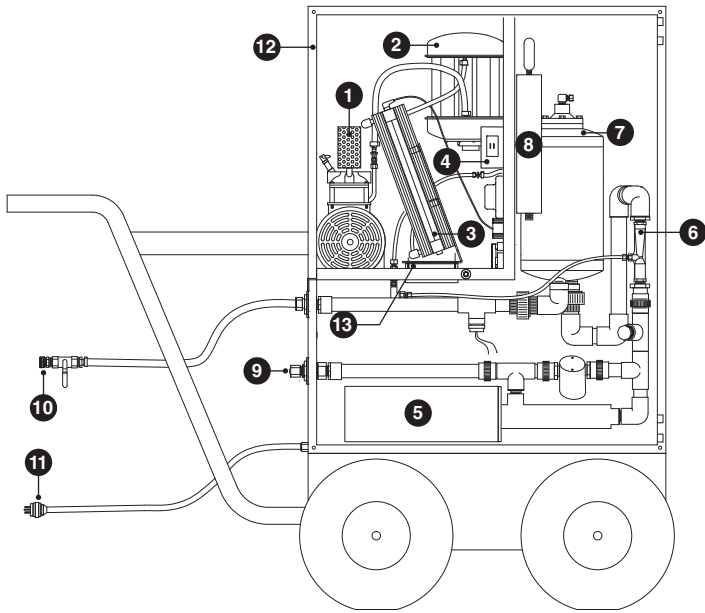

AGW-0500 Components

1. Air Compressor
2. Oxygen Concentrator
3. Ozone Generation Cell
4. G.F.C.I.
5. Multi-Stage Water Pump
6. Ozone Injector
7. Ozone Degas Chamber
8. Heated Catalytic Ozone Destruct
9. Water In
10. Ozonated Water Out / Control Valve
11. 110V Power Cord with 3-Prong Plug
12. Stainless Steel, Waterproof Enclosure
13. Air Filter (Dry Section)



AGW-0500 Accessories

1. Tank Spray Wand
2. Long Spray Wand
3. Short Spray Wand
4. Barrel Spray Wand
5. CIP Adapter
6. Hot Water Protection Device

Figure 1: AGW-0500 Components & Accessories

moisture fouling). The manganese dioxide and heat offer redundant ozone destruct capabilities.

5. **Ozone-Enriched Water Out:** Ozone-enriched water exits the unit through the supplied hose. All available hose attachments are specifically sized to provide the exact pressure and flow parameters necessary to allow the system to function correctly.

SECTION 2 Installation

2A. Location

The AGW-0500 cart is designed to be conveniently rolled to a location close to your process. This can be a level location either indoors or outdoors. Allow for access to protected electrical power and required water connections.

2B. Electrical

Main Power Supply Circuit: The AGW-0500 is supplied with a standard 50 foot power cord. Plug cord into standard grounded 20 Amp G.F.C.I. type receptacle only.

2C. Plumbing

The cabinet of the AGW-0500 contains all plumbing required for ozone injection into your supply water.

SECTION 3 Operation

3A. Control Panel Overview

1. Front Panel
 - a. Illuminated On/Off Switch
 - b. Pump Power Indicator Light (only one when ball valve for hose is fully open and water is flowing)
 - c. Ozone Power Indicator Light (only one when Pump Power Indicator Light is on and unit is producing ozone)

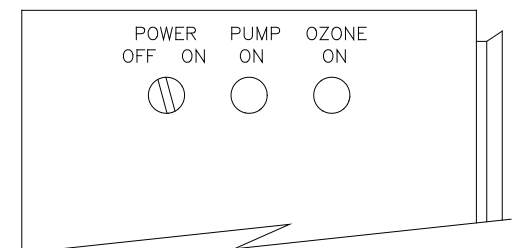

Figure 2: AGW-0500 Front Panel

2. Inside Panel
 - a. G.F.C.I.
 - b. Vacuum: Indicates that vacuum is out of range. The light will be lit for low vacuum conditions, indicating low sourcewater flow.
 - c. High Ozone Cell Temperature: Indicates the ozone cell temperature is over 150°F.
 - d. Hour Meter

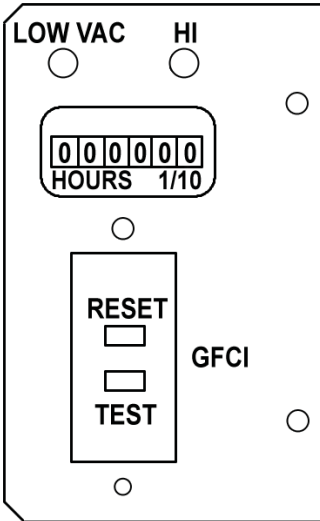

Figure 3: AGW-0500 Inside Panel

3B. System Start-Up

1. Install optional Hot Water Protection Device as necessary.
2. Install a standard garden hose (min. 3/4") into the fitting located on the cabinet. **(Source water must be a minimum of 10 GPM @ 20 psi.)**
3. Select and install the appropriate attachment. (Tank/Barrel Spray Wand, Fan Wand or CIP Fitting)
4. Open Water Control Valve on the end of the spray hose.
5. Turn the source water on. **(Allow 2 minutes to prime pump and purge air from system before turning on pump.)**
6. Plug the system into a specified receptacle.
7. Turn the system on.
8. Open the control valve and begin spraying.

3C. System Shut-Down

1. Close the Control Valve.
2. Turn the system off.
3. Unplug the system from the power source.
4. Turn the source water off.
5. Open the Control Valve to relieve pressure and drain excess water.

6. Disconnect the garden hose from the fitting. (Some water will drain out.)
7. If unit will be stored in freezing temperatures or for extended periods of time, the pump must be drained by removing the drain plug to prevent pump damage.

3D. Standard Operating Procedures

NOTE: The AGW-0500 provides a final sanitizing rinse, leaving no residual.

3D-1. Surface Sanitation

The spray can be directed on all wettable wood, metal, concrete, and plastic surfaces including: floors, drains, walls, conveyors, containers, external or internal tanks; tables, trays, bowls, and general equipment. (If the ozone spray is being applied in a very small, enclosed, poorly ventilated area, it may be necessary to wear a standard ventilator to avoid the inhalation of ozone gas. **CAUTION:** Exposure to greater than 0.1 ppm ozone gas can irritate eyes and sensitive lung tissue. Please see the Safety Section 6 for further details and a MSDS on ozone.)

Based on industry experience, the amount of time necessary to attain sanitation depends on the amount of debris found in the area to be cleaned. Sweep or remove heavy surface dirt first to expedite the ozone sanitation process. Time estimates for proper sanitation are difficult to predict due to the variety of areas, surface materials and contaminants. However, experience and studies support that 0.5 to 2 minutes of spray time is generally all that is necessary for complete sanitation. DEL recommends that end-users utilize their own sanitation efficacy testing protocol to determine necessary spray time.

3D-2. Wine Barrel Sanitation

Ozone is anti-microbial. Based on industry experience, the following chart provides ozonation time estimates for typical wood barrel sanitizing used in conjunction with a hand-held Barrel Spray Wand:

Sanitation Requirements	STEP 1 Hot Water	STEP 2 Ozone Enriched Cold Water
1. Total reduction of Acetobacter (which contributes to Volatile Acidity) 2. Total reduction of Brettanomyces (or all wild yeasts) 3. Overall barrel freshening	None	1.0 - 2.0 Minutes
4. Light Tartrates (+ 1, 2, 3)	1.0 Minutes	1.0 Minutes
5. Heavy Tartrates (+ 1, 2, 3)	2.0 Minutes	1.0 Minute

3D-3. AGW-0290 Contact Tank for 2-Up Barrel Washer

The AGW-0290 (See Figure 4, page 5) is a 30 gallon tank designed to compensate for the water flow difference between a 2-Up Barrel Washer, which flows at ~13 GPM, and the AGW-0500, which flows at 9 GPM. The 30 gallons of ozonated water that is stored in the AGW-0290 will allow the 2-Up to operate with adequate flow for approximately 10 minutes. During barrel changes, the system will catch up and recharge the water for the next pair of barrels.

The AGW-0290 is connected to the outlet from the AGW-0500 and to the inlet on the 2-Up. The AGW-0500 is started using normal start-up procedure and is allowed to fill the AGW-0290 (should take approximately 3 minutes). NOTE: Once the tank is filled, the AGW-0500 pump will automatically shut off. At this time, the 2-Up can be operated for a normal wash cycle (or up to approximately 10 minutes).

The AGW-0500 will continue running until the AGW-0290 is filled again, at which time another barrel wash cycle can be started.

Each time the 2-Up is used (following a period of non-use), it is necessary to do a duplicate cycle as the first 30 gallons of water in the AGW-0290 will no longer be ozonated (ozone in water usually reverts back to oxygen within approximately 20 minutes).

3D-4. Tank Sanitation

Attach the tank spray wand to the AGW-0500 outlet hose. Lower wand into tank and spray as usual. The spray wand delivers a 360° spray pattern with a six (6) foot radius – effectively covering a twelve (12) foot sphere. If the tank is larger than this it may be necessary to continually adjust the position of the wand so that the entire inside of the tank is sprayed thoroughly. Recommended spray time for sanitation is approximately 10-30 minutes, assuming a clean tank to start.

NOTE: In all cases, the tanks should be pre-cleaned and free of debris. In the event a tank is extremely soiled, the sanitation time will need to be increased. Pre-rinsing with hot water or surfactant wash may be necessary for tanks that are heavily soiled.

3D-5. CIP

CIP Operation: The AGW-0500 can be used on CIP systems meeting the 9 GPM requirement. Using the CIP fitting, attach the AGW-0500 outlet hose to the CIP inlet. Recommended run time is approximately 10-30 minutes.

There are two ways to measure the amount of ozone at the discharge point of the CIP system:

- 1. Dissolved Ozone Monitor (AGW-0100)**
This is by far the most accurate method of measuring the ozone in the water. A dissolved ozone monitor may be used to accurately measure the ozone level in the discharge water of the CIP system and will insure the desired level for sanitizing has been reached through the entire system. It is necessary to assemble a small collection/monitoring tank with a sensor probe attachment location.
- 2. Indigo Blue Ampules with Colorimeter (Hach AccuVac Test Kit)**
This is also a satisfactory method but will only measure ozone levels in the water up to 1.6 ppm. If levels higher than this are desired at the point of discharge, a dissolved ozone monitor will be required.

ORP Monitor

This method cannot be used because the ORP monitor is an ineffective measurement of dissolved ozone concentrations greater than about 0.5 ppm.

3D-6. Testing Dissolved Ozone Level (HACH) in System Effluent Water Flow

Materials Required

1. HACH Indigo Blue AccuVac high range dissolved ozone test kit (DEL P/N 6-0116)
2. 5 gallon plastic pail (pre-cleaned)
3. Cold potable supply water for AGW-0500

Procedure

1. Familiarize self with HACH AccuVac test kit.
2. Start-up AGW-0500, place and hold spray wand in 5 gallon pail, and allow to flow for three to four minutes (**NOTE: ensure the tip of the spray wand is approximately two inches above the bottom of the pail.**)
3. Thoroughly rinse hands, ampule, and plunger under the pail's overflow for one minute.
4. Immediately take a water sample using the ampule (following the HACH instructions) from

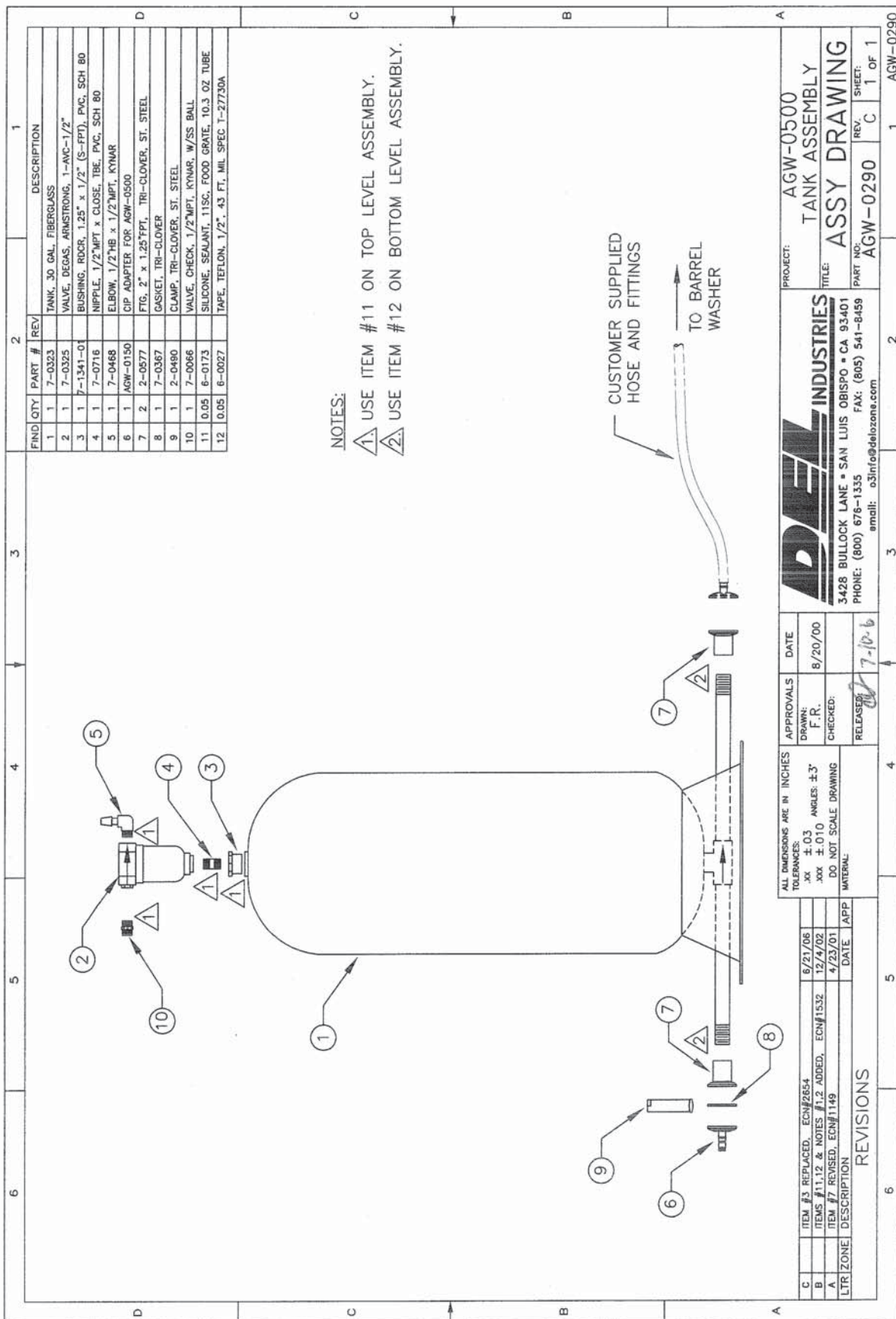

Figure 4: AGW-0290 Contact Tank for 2-Up Barrel Washer

the middle of the pail at least one inch below the water surface.

5. Gently shake the ampule.
6. Immediately compare the color of the ampule to the supplied color wheel with thumb covering the numerical readings. Once a color match is determined, move thumb and take numerical reading.

SECTION 4 Maintenance & Service

4A. Preventative Maintenance Schedule

DAILY:

1. Check ozone generator for proper operation. Make sure green indicator lights are lit during operation.

MONTHLY:

1. Turn off system, unplug from power.
2. Remove and clean air filter located under "dry section".
 - Remove plastic cover.
 - Rinse filter in warm, soapy water and allow to dry.
 - Replace filter. (DEL P/N 7-0398)
3. Perform general cleaning of cabinet exterior.
4. Using clean/dry compressed air, blow out the interior of cabinet, taking special care around small components and wiring.
5. Check for debris in the debris screen located in the source water inlet fitting. Clean & reinstall.
6. Check air in the tires and their general condition.

ANNUALLY:

1. Remove and replace compressor air filter cartridge using DEL P/N 7-1132.

EVERY 10,000 HOURS:

1. Rebuild compressor.
 - Purchase compressor rebuild kit. (P/N 2-0931-01) - See Section 5B for replacement parts list
 - Follow instructions in compressor rebuild kit.

EVERY 18,000 HOURS:

1. Replace ozone generation cell. (P/N 9-0927)

4B. Troubleshooting

Knowledge of electrical applications is required for troubleshooting. Contact a certified electrician if you are unsure of your ability to service the equipment. If any condition persists, call 800-676-1335 or for international call 805-541-1601 for technical assistance.

Symptom: "PUMP ON" green indicator light out when POWER switch is in the "ON" position and ball valve on hose is fully open with water flowing.

1. No power to the AGW-0500 from the power supply.
 - a. Check the circuit breaker at the facility power distribution box.
 - b. Check for loose connections or wiring breaks from the power distribution box to the AGW-0500.
2. G.F.C.I. has tripped.*
 - a. Check power cord for breaks in insulation. Repair. Reset G.F.C.I.
3. Circuit breaker has tripped.*
 - a. Check for source of power overload on the circuit. Correct. Reset circuit breaker.

*If G.F.C.I. or breaker continue to trip after reset, call for technical assistance.

Symptom: "OZONE ON" green indicator light out when switch is in the "ON" position and "PUMP ON" light is on.

1. Check inside control panel for fault lights.
 - a. See Low Vac & Hi Temp fault light sections.
2. Check internal fuse.
 - a. Replace if blown. (2 amp - AGC 2)
3. Cabinet door ajar.
 - a. Close and latch door.

Symptom: "LOW VAC" red indicator light is on, indicating out of range vacuum is being supplied.

1. Check pump and ensure water is flowing through injector.
2. Check water supply. (10 GPM at 20 psi minimum required).
3. Check for debris in debris screen located in inlet water fitting.

Symptom: "HIGH TEMP" red fault light is on, indicating ozone module temperature over 150°F.

1. Cabinet ventilation is blocked.
 - a. Check air filter located under fan on the bottom of "dry section" enclosure.
 - b. Clear blockage or clean filter.
 - c. Restart system and allow transformer to cool. When temperature returns to normal, system will return to normal operation.
2. Excessive ambient temperature in operation area.
 - a. Generator should not be exposed to ambient temperatures above 100°F.

SECTION 5 Replacement Parts & Order Info

5A. Ordering Information:

For replacement parts call DEL at 1-800-676-1335 or for international call 805-541-1601.

Be prepared with the following information:

- Customer Name
- Customer Address
- DEL Model Number
- DEL Serial Number
- Date Purchased
- Proof of Purchase

5B. Standard Replacement Parts List:

1. Compressor rebuild kit, AGW-0500...2-0895-01
2. Cabinet Air Filter Cartridge7-0398
3. Compressor Air Filter Cartridge7-1132
4. Ozone Generation Cell.....9-0927

SECTION 6 Ozone Overview & Safety Procedures

6A. Ozone Use & Technology Overview

6A-1. Relative Strength of Ozone

The following compares the strengths of several common oxidizing reagents:

Oxidizing Reagent	EOP vs. Cl ₂
Elemental Fluorine	2.25
Hydroxyl Radical	2.05
Ozone.....	1.52
Hydrogen Peroxide.....	1.30
Hypochlorite	1.10
Chlorine.....	1.00
Chlorine Dioxide.....	0.93
Bromine.....	0.57

The following compares the CT values for water of ozone versus forms of chlorine:

Microorganism	Disinfectant			
	Ozone (pH 6 - 7)	Preformed Chloramine (pH 8 - 9)	Chlorine Dioxide (pH 6 - 7)	Free Chlorine (pH 6 - 7)
<i>E. coli</i>	0.02	95-180	0.4-0.75	0.034-0.05
Polio 1	0.1-0.2	770-3740	0.2-6.7	1.1-2.5
Rotavirus	0.006-0.06	3810-6480	0.2-2.1	0.01-0.05
<i>G. Lamblia</i> cysts	0.5-0.6	--	--	47-150
<i>G. muris</i> cysts	1.8-2.0	1400	7.2-18.5	30-630

6A-2. Materials Selection

Materials	Aqueous Ozone 0-3 ppm Freshwater
Metals: Copper Brass 316L Stainless Steel	☆ ☆ ☆☆☆☆
Plastics: ECTFE (Halar) PTFE (Teflon) PVC (rigid) PVC (flexible) PVDF (Kynar)	☆☆☆☆ ☆☆☆☆ ☆☆☆ ☆☆☆ ☆☆☆☆
Elastomers: FPM (Viton)	☆☆☆ (gasket)
LEGEND: ☆ = Not Recommended ☆☆☆ = Fair ☆☆☆☆ = Good ☆☆☆☆☆ = Very Good	

6A-3. Micro-Flocculation and Oxidation

Ozone oxidizes the following metals (know as micro-flocculation), enabling their removal via filtration:

- Iron
- Copper
- Manganese
- Zinc
- Arsenic

Ozone neutralizes "nuisance" compounds - most commonly, hydrogen sulfide.

6A-4. Factors Affecting Sanitation

The following factors will affect the ability of ozone to effectively act as a sanitizer:

- Type and level of contaminant
- Physical/chemical parameters of the environs
- Exposure time
- Temperature
- Concentration
- Water chemistry and pH
- Cleanliness
- Microbial attachment

6B. General Safety Information

6B-1. Ozone Properties

- Colorless to blue gas (greater than -169°F)
- Characteristic odor often associated with electrical sparks or lightning in concentrations of less than 2 ppm
- Severe irritant above 1-2 ppm
- Generally exists as a gas
- Highly chemically reactive
- Non-flammable, non-carcinogenic
- Hazardous polymerization can occur
- Spontaneously decomposes to oxygen gas

6B-2. Ozone Uses

- Air and water disinfection
- Surface sanitation
- Water treatment plants
- Bottled water, irrigation, community water supplies, swimming pools/spas, etc.
- Aquariums/life support
- Agricultural wash water
- Wastewater treatment
- Mold and bacteria control in cold storage

6B-3. AGW-0500 Safety Features

The AGW-0500 has a water-proof, stainless steel enclosure, inside which ozone is automatically and immediately injected into the water flow. Any ozone which does not dissolve into the water is separated off in the degas chamber and eliminated in the heated catalytic ozone destruct. The design of this enclosed, self-contained system eliminates the release of gaseous ozone from the unit. In addition to ozone safety, the following general safety features are built-in to the AGW-0500:

- Door safety interlock switch - disables high voltage power supply when open or improperly latched
- Circuit Breaker, G.F.C.I. Breaker, Fuse
- Vacuum Switch - stops operation in the event of low water flow
- Flow Switch - stops operation in the event of low water flow
- Ozone cell high temperature indicator
- Interlocked sensors and regulating devices
- Startup/shutdown sequences and fault protection
- Multistage water pump to control flow rate
- Ozone is supplied under negative pressure (induction - i.e. a leak will draw air into the system).

Slight off-gassing of ozone can occur from the spray water that is produced by the AGW-0500 (the physical properties of ozone make this unavoidable). Laboratory and field testing in varying environments indicate that ozone off-gas levels from the spray water produced by the AGW-0500 do not exceed 0.1 ppm (the permissible exposure level (PEL) or time weighted concentration for gaseous ozone to which workers may be exposed averaged over 8 hours, 5 days a week (OSHA)). Gaseous ozone concentrations above 0.02 ppm are detectable by humans.

Inasmuch, Sections 6C - 6H of this manual discuss relative issues regarding safety and monitoring of gaseous ozone.

6C. Hazards

6C-1. Health Hazards - Detection Levels

Gaseous ozone can be detected in air by its distinctive odor at concentrations of about 0.02 ppm. Although each nose varies, olfactory fatigue occurs quickly. Initial small exposure may reduce cell sensitivity and/or increase mucous thickness producing a resistance to low gaseous ozone levels. As a result, **DO NOT RELY ON ODOR AS A WARNING OF HIGH OZONE CONCENTRATIONS.**

The permissible exposure level (PEL) or time weighted concentration for gaseous ozone to which workers may be exposed is 0.1 ppm averaged over 8 hours, 5 days a week (OSHA). The short term exposure limit is 0.3 ppm averaged over 15 minutes. The concentration of 5.0 ppm ozone in air is generally accepted as Immediately Dangerous to Life or Health (IDLH).

6C-2. Health Hazards - Effects on Humans

Gaseous ozone acts as a primary irritant, affecting mainly the eyes, upper respiratory tract and the lungs. Inhalation produces various degrees of respiratory effects from irritation to pulmonary edema (fluid in lungs). Short exposure to 1-2 ppm concentrations causes headache as well as irritation to the respiratory system but symptoms subside when exposure ends. High concentrations of ozone produce severe irritation to the eyes and respiratory system. Exposure above the ACGIH/OSHA limits may produce nausea, chest pain, coughing, fatigue, reduced visual acuity and pulmonary edema. Symptoms of edema from excessive exposure can be delayed one or more hours. There is no threshold limit and so no exposure (regardless of how small) is theoretically without effect from ozone's strong oxidative ability.

TOXIC EFFECTS OF GASEOUS OZONE	
OZONE CONCENTRATION (ppm)	EFFECT
0.01 - 0.10	Range of odor threshold
0.1	Permissible concentration (8 hour work day)*
0.3	Permitted short-term exposure (15 min.)*
0.01 - 1.0	Headaches, irritation to respiratory tract, severe irritation to eyes
1.0 - 10.0	Nausea, chest pain, coughing, fatigue, reduced visual acuity, pulmonary edema
5.0	Immediately Dangerous to Life or Health (I.D.L.H.)*
> 20.0	Can be fatal after 1 hour
> 50.0	Can be fatal after 1/2 hour
	* Regulatory Levels

6C-3. Hazards - Electrical

Turn OFF all power switches and disconnect power cord from power source receptacle before performing service work. Failure to do so could result in serious injury or death. Operate the AGW-0500 on a near level surface with safe access to electrical power. Connect the AGW-0500 to a G.F.C.I. type receptacle. Do not bury the electrical cord. To reduce risk of electrical shock, replace damaged cord immediately.

6C-4. Hazards - Fire

Ozone is nonflammable. Decomposition of ozone into oxygen gas, O₂, can increase strength of fire. Ozone is unstable at room temperature and spontaneously decomposes to oxygen gas. Avoid ignition sources such as heat, sparks, and open flame. Keep away from strong reducing agents and combustible materials such as grease, oils, and fats.

6C-5. Hazards - Chemical Action

Ozone is chemically incompatible with all oxidizable materials, both organic and inorganic.

6D-4. Respiratory Protection

A disposable respirator (3M #N95 8214/8514 - Minneapolis, MN, www.3m.com) is recommended for relief against ozone levels up to 10 times the OSHA PEL or applicable government occupational exposure limits, whichever is lower.

6D-5. Education & Training

The education and training of workers is the responsibility of the employer. An effective training program must be practical, based on written work procedures and be specific to both the job-site and the tasks to be performed. Training shall also include the responsibilities and responses of workers in an emergency. The employer shall ensure, through the education and training program, that all workers are able to work without risk to themselves or others around them. All workers must clearly understand their responsibilities with regard to not only specific work procedures, but also the need to report all hazards, accidents or incidents and injuries.

All routine work and emergency procedures shall be reviewed jointly by management and employees at least annually.

6D. Precautions for Safe Handling & Use**6D-1. Ozone Monitors**

Ambient ozone monitoring equipment should be installed in the areas where ozone is being generated or applied. See Monitoring Section 6E. Self-adhesive ozone monitor badges, such as the Chromair® System by K&M Environmental (Virginia Beach, VA, www.kandmenvironmental.com), may be used for personal or area monitoring for exposure times ranging from 5 minutes to 10 hours.

6D-2. Ventilation

It is mandatory that general and local exhaust ventilation be provided to dilute and disperse small amounts of ozone into the outside atmosphere. Federal, state, and local regulations must be followed.

6D-3. Emergency Procedure

Due to the short life of ozone, evacuation and ventilation is all that is generally required in the event of a high ambient ozone alarm. All ozone generating and delivery equipment should be shut down (manually or automatically by alarm) and a high speed fan activated to dilute and disperse ozone to the atmosphere. Personnel should evacuate the affected area until levels are returned to below 0.1 ppm.

6E. Monitoring**6E-1. Location of Monitors**

Ambient ozone detection monitors shall be located to monitor ozone room air and production/plant room air for indoor applications.

6E-2. Monitoring Equipment**OZONE IN AIR**

Electronic Ambient Ozone Monitor

1. Shall measure the level of ozone present in the room where ozone equipment is located.
2. The monitor shall include both visible and audible alarms. The EcoZone™ Model EZ-1 portable ambient ozone analyzer by EcoSensors, Inc. is recommended for use with the AGW-0500.
 - a. EcoZone™ Model EZ-1 features:
 - Constantly monitors work environment
 - O₃ concentration shown by a multi-color display from green (safe) to yellow (caution) to red (danger)
 - No installation required
 - Easily understood by non-technical personnel
 - Field work and "walk around" analyses possible via power from internal rechargeable batteries

- Compatible with EcoSensor VOC and O₃ sensing, monitoring, and control products
- EcoZone™ Model EZ-1 specifications:
- Range: 0.02-0.14 ppm O₃
 - Bar graph display: normally green, yellow at 0.05 ppm (caution), red at 0.1 ppm (danger)
 - Response time: with a few seconds of O₃ reaching the sensor
 - Accuracy: within 20% in the 0.05-0.1 ppm range
 - Recommended calibration check annually
 - Temperature Range: 18-37°C (65-100°F)
 - Measurement principle: HMOS (HeatedMetal Oxide Semiconductor) sensor
 - Size: 85 x 35 x 60 mm (3 1/4" x 1 3/8" x 2 3/8")
 - Weight: 154 grams (6 oz.)
 - Power Requirements: 12-24 volts DC at 300-500 mA. AC adapters available worldwide.
 - Batteries: self-contained NiMH. Approximately 2 hour capacity. Recharged by AC adapter overnight.

Badge-Type Ambient Ozone Monitor

1. Shall measure the level of ozone present in the room where ozone equipment is located.
 2. The ChromAir® System ozone badge (K&M Environmental P/N 380010-10; www.kandmenvironmental.com; 1-800-808-2234) may be used for personnel or area monitoring for exposure times ranging from 5 minutes to 10 hours. For higher resolution, the ChromAir ozone badge may be used in conjunction with the ChromAir ozone color comparator.
 - a. ChromAir System features:
 - Constantly monitors work environment
 - Accurate measurements
 - Ease of use - requires minimal training
 - Cost effective - offers the most inexpensive air sampling solution available
- ChromAir System specifications:
- Color change: blue to white
 - Exposure range: 0.08–1.6 ppm • hr
 - Max. sampling time: 10 hours
 - Min. sampling time: 5 minutes
 - Relative humidity range: 20% - 90%
 - Face velocity range: 10-165 cm/sec
 - Temp. range: 16°C - 30°C (61°F - 86°F)
 - Light effect - sunlight: not recommended
 - Light effect - visible: no effect
 - Dimensions: 10.5 cm x 5.5 cm x 0.25 cm
 - Weight: 11 g
 - Refrigerated shelf life: 1 year

Other ambient ozone monitors are also available. Contact DEL for further information.

OZONE IN WATER

The ozone concentration in water can be measured in different ways.

1. Oxidation Reduction Potential (ORP) monitor measures the effective biocidal activity of dissolved ozone in water in millivolts and can be converted to mg/l (ppm). **NOTE: ORP is an ineffective measurement of ozone concentrations greater than about 0.5 ppm.**
2. Dissolved Ozone monitors measure levels of dissolved ozone in water (mg/l or PPM). The HACH Indigo Blue AccuVac high range dissolved ozone test kit (DEL P/N 6-0116) is an inexpensive colorimetric test. Electronic, in-line dissolved ozone monitors are also available. Contact DEL for further information.

6E-3. Ozone Detection Data Log

In addition to automatic chart recorders, operators should log ozone monitor output. Record ozone output data twice per shift (maximum 12 hour shift). If system does not have an automatic chart recorder, record data every 4 hours, regardless of shift changes. (**See Daily Data Log, Appendix "A"**).

6F. First Aid Procedures

6F-1. General

First Action:

1. DO NOT PANIC.
2. If exposure to gaseous ozone causes headaches or shortness of breath, immediately remove the worker to a fresh air environment.

Second Action:

1. Ensure there is no more danger to yourself or the worker.
2. Workers who have been exposed to low concentrations of ozone should be given oxygen to breathe while under the observation of trained personnel.
3. If exposure is severe, send for medical assistance immediately.

6F-2. Inhalation

First Action:

1. Assess worker's breathing.
2. All unconscious workers must be placed in the drainage position (on their sides), so that fluids can drain from the airways once breathing has been restored.

3. Check pulse.

Second Action:

1. If breathing has ceased, start artificial respiration (rescue breathing is the most effective method) until breathing has been restored.
2. Send for medical assistance immediately.
3. If absent, begin cardiopulmonary resuscitation (CPR).

6F-3. Eye Contact

First Action:

1. Effective irrigation should start immediately. Eyes should be irrigated for 30 minutes by the clock with running tap water or preferably normal saline.

Second Action:

1. Effective irrigation must be continued while en-route to hospital.

6F-4. Precautions

Workers with a previous cardiopulmonary (heart and lung) condition must consult their physician prior to working in an area in which they may be exposed to ozone. Significant alterations in cardiopulmonary functions have been documented when such workers have been exposed to low concentrations of ozone.

6F-5. Emergency Information Form

An emergency information form (**See Appendix "B"**) should be filled out prior to operation of ozone generator.

6G. MSDS

See Appendix "C" for full MSDS

DEL OZONE COMMERCIAL PRODUCT LIMITED TWO YEAR WARRANTY

The limited warranty set forth below applies to products manufactured by DEL OZONE – 3580 Sueldo Street, San Luis Obispo, California 93401, and sold by DEL OZONE or its authorized dealers. This limited warranty is given only to the first retail purchaser of such products and is not transferable to any subsequent owners or purchasers of such products. Systems sized 65 grams or greater require factory commissioning and startup to maintain warranty as set forth below.

DEL OZONE warrants that DEL or DEL authorized dealers will repair or replace, at DEL's option, any part of such products proven to be defective in materials or workmanship within two (2) years of the date of receipt. Parts are covered under the two (2) year warranty when and only when the stated maintenance requirements are met. Contact tanks and degas valves have a ninety (90) day warranty. Compressor(s) must be maintained per operation and maintenance manual. Required maintenance includes a compressor rebuild after one (1) year or every 8,760 hours, whichever is reached first. Warranty does not include parts for compressor(s) rebuild kit(s), or other consumable items. See owner's manual for complete maintenance details. This Warranty specifically excludes any components not manufactured by DEL OZONE that are external to the products covered, such as pumps, air compressors, monitors, tanks, or related components. DEL OZONE will assist with warranty claims for such components purchased through DEL OZONE; limited to the extent of the manufacturer's standard warranty. ANY REPAIR OR REPLACEMENT WILL BE WARRANTED ONLY FOR THE BALANCE OF THE ORIGINAL TWO (2) YEAR WARRANTY PERIOD

NOTE: USE ONLY DEL AUTHORIZED DEL REPLACEMENT PARTS. USE OF ANY OTHER PART(S) WILL VOID THIS WARRANTY.

Any replaced parts must be returned to DEL OZONE for warranty evaluation.

THIS LIMITED WARRANTY DOES NOT INCLUDE ANY OF THE FOLLOWING:

- (a) Any labor charges for troubleshooting, removal, or installation of such parts.
- (b) Any repair or replacement of such parts necessitated by faulty installation, improper maintenance, improper operation, misuse, abuse, negligence, accident, fire, flood, repair materials, and/or unauthorized accessories.
- (c) Any such products installed without regard to required local codes and accepted trade practices.
- (d) Damage to unit caused by water backflow;
- (e) Any implied warranty of merchantability or implied warranty of fitness for particular purpose, and such warranties are hereby disclaimed.
- (f) DEL Ozone shall not be liable under any circumstances for loss of use of such product, loss of profits, direct damages, indirect damages, consequential damages, and / or incidental damages.

This warranty gives you specific legal rights. You may have other rights which vary from state to state.

Extended Warranties and Service Agreements are available. Contact DEL for additional details.

TO OBTAIN WARRANTY SERVICE:

DEL OZONE
3580 Sueldo, San Luis Obispo, CA 93401
Customer Service Number: (800) 676-1335
Fax Number: (805) 541-8459
E mail: service@delozone.com

PROVIDE:

1. Project, contact name, mailing address and telephone.
2. Installer/Mechanical Contractor.
3. Unit Part Number, Serial Number, and date of purchase.
4. The date of failure.
5. A description of the failure.

After this information is provided, DEL Ozone may release a *RETURN GOODS AUTHORIZATION (RGA) NUMBER*. After receiving the RGA number the part in question must be returned to DEL Ozone, freight prepaid, with the RGA number clearly marked on the outside of the package. All preauthorized defective parts must be returned to DEL Ozone within thirty (30) days. Under no circumstances may any product be returned to DEL Ozone without prior authorization. Returns without the assigned RGA number on the outside of the package will be refused and shipped back to the sender at their expense. Upon receipt of preauthorized returned goods, DEL Ozone will repair or replace, at DEL Ozone's option, the defective product(s) and return them (freight prepaid for products under warranty). Buyer's acceptance of the product and use thereof constitutes acceptance of these terms.

4-1370-01_Rev.D

APPENDIX “A”

DAILY DATA LOG

APPENDIX “B”

EMERGENCY INFORMATION

APPENDIX “C”

SAFETY

OZONE

Material Safety Data Sheet

SECTION I: MATERIAL IDENTIFICATION							
IDENTITY: OZONE (Gaseous)	ISSUED: February, 1992						
FORMULA: O ₃	REVISED: March, 2009						
<p>Description (origin/uses): Occurs in atmosphere from UV light action on oxygen at high altitude. Commercially obtained by passing air between electrodes carrying a high voltage alternating current. Also found as a by-product in welding areas, high voltage equipment, or UV radiation.</p> <p>Ozone is used as an oxidizing agent in air and water disinfection: for bleaching textiles, oils, and waxes; organic synthesis as in processing certain perfumes, vanillin, camphor; for mold and bacteria control in cold storage.</p>							
<p>Cautions: A powerful oxidizing agent, ozone generally exists as a gas and is highly chemically reactive. Inhalation produces various degrees of respiratory effects from irritation to pulmonary edema (fluid in lungs) as well as affecting the eyes, blood, and central nervous system.</p>							
<p>Manufacturer/Supplier: On-site generation, equipment available from various suppliers, including:</p> <table style="width: 100%; border: none;"> <tr> <td style="width: 50%;">DEL Ozone</td> <td style="width: 50%;">Phone: (805) 541-1601</td> </tr> <tr> <td>3580 Sueldo Street</td> <td>FAX: (805) 541-8459</td> </tr> <tr> <td>San Luis Obispo, CA 93401</td> <td></td> </tr> </table>		DEL Ozone	Phone: (805) 541-1601	3580 Sueldo Street	FAX: (805) 541-8459	San Luis Obispo, CA 93401	
DEL Ozone	Phone: (805) 541-1601						
3580 Sueldo Street	FAX: (805) 541-8459						
San Luis Obispo, CA 93401							
SECTION II: INGREDIENTS AND HAZARDS							
Ozone, CAS No. 10028-15-6: NIOSH RTECS No. RS8225000							
1991 OSHA PELs 8-hr TWA: 0.1 ppm vol. (0.2 mg/m ³) 15-min STEL: 0.3 ppm vol (0.6 mg/m ³)	1991-1992 ACGIH TLV Ceiling: 0.1 ppm (0.2 mg/m ³)						
1990 IDLH 10 ppm	1990 DFG (Germany) MAK TWA: 0.1 ppm (0.2 mg/m ³)						
1990 NIOSH REL Ceiling: 0.1 ppm vol. (0.2 mg/m ³)	Category 1: Local Irritant Peak Exposure Limit: 0.2 ppm 5 min momentary value, 8 per shift						
<p>Other Designations: Triatomic oxygen: CAS No. 10028-15-6, NIOSH RTECS No. RS8225000</p>							
SECTION III: PHYSICAL DATA							
Boiling Point: -169° F	Melting Point: -315.4° F (-193° C)						
Vapor Pressure: >1 ATM	% Volatile by Volume: 100%						
Vapor Density (AIR = 1): 1.6	Molecular Weight: 48 Grams/Mole						
Solubility in Water: 0.49 ml @ 32° F (0° C), 3 ppm @ 20° C	pH: Not Listed						
	Critical Temperature: 10.22° F (-12.1° C)						
<p>Appearance and Odor: Colorless to blue gas (greater than -169° F): characteristic odor often associated with electrical sparks or lightning in concentrations of less than 2 ppm and becomes disagreeable above 1-2 ppm. CAUTION: Olfactory fatigue develops rapidly, so do not use odor as a preventative warning device.</p>							
SECTION IV: FIRE AND EXPLOSION HAZARD DATA							
Flash Point: Nonflammable							
Extinguishing Media:	Use large amounts of water spray or fog to put out fires involving ozone. Use appropriate fire-fighting techniques to deal with surrounding material.						
<p>Special Fire Fighting Procedures: Wear a self contained breathing apparatus with full face pieces operated in a pressure-demand or other positive-pressure mode.</p>							
<p>Unusual Fire/Explosion Hazards: Decomposition of ozone into oxygen gas, (O₂), can increase strength of fire.</p>							
SECTION V: REACTIVITY DATA							
<p>Stability: Ozone is not stable. Hazardous polymerization cannot occur.</p>							
<p>Chemical Incompatibilities: Ozone is chemically incompatible with all oxidizable materials, both organic and inorganic.</p>							
<p>Conditions to Avoid: Ozone is unstable at room temperatures and spontaneously decomposes to oxygen gas. Avoid ignition sources such as heat, sparks, and open flame. Keep away from strong reducing agents and combustible materials such as grease, oils, and fats.</p>							
<p>Products of Hazardous Decomposition: Ozone spontaneously decomposes to oxygen gas, even at room temperatures.</p>							

4-0697_ Rev.B

SECTION VI: HEALTH HAZARD DATA

Carcinogenicity: Ozone is not listed as a carcinogen by the NTP, IARC, or OSHA.

Primary Entry: Inhalation

Target Organs: Respiratory system, eyes, blood.

Summary of Risks: There is no true threshold limit and so no exposure (regardless of how small) is theoretically without effect from ozone's strong oxidative ability. Ozone passes straight to the smallest bronchioles and alveoli and is not absorbed by mucous membranes along the way. Initial small exposure may reduce cell sensitivity and/or increase mucous thickness producing a resistance to low ozone levels. Short exposure to 1-2 ppm concentrations causes headache as well as irritation to the respiratory tract, but symptoms subside when exposure ends. High concentrations of ozone produce severe irritation of the eyes and respiratory tract. Exposure above the ACGIH/OSHA limits produce nausea, chest pain, coughing, fatigue, reduced visual acuity, and pulmonary edema. Symptoms of edema from excessive exposure can be delayed one or more hours. Inhalation of >20 ppm for an hour or more (>50 ppm for 1/2 hour) can be fatal.

Acute Effects: Acute damage from ozone appears to be mainly from its oxidizing effect on contact with tissue.

Chronic Effects: Respiratory disease. Deleterious effects on lungs and acceleration of tumors have been reported.

Medical Conditions Generally Aggravated by Long-Term Exposure: History of respiratory or heart disorders.

First Aid: Remove from ozone containing air, get prompt medical help*, administer oxygen if necessary.

Eye Contact - Gently lift eyelids and flush eyes continuously with flooding amounts of water for 15 minutes or until transported to a medical facility*.

Inhalation - Remove exposed person to fresh air, support breathing, administer humidified oxygen as needed, get medical help*.

Ingestion - Highly unlikely since ozone is a gas until -169° F,

* **GET MEDICAL ASSISTANCE = APPROPRIATE IN-PLANT, PARAMEDIC, or COMMUNITY.** Get prompt medical assistance for further treatment, observation, and support after first aid.

SECTION VII: PRECAUTIONS FOR SAFE HANDLING AND USE

Steps to be Taken in Case of Spill/Leak:

1. Discontinue production
2. Isolate and vent area
3. Immediately notify personnel
4. Deny entry
5. Follow applicable OSHA regulations

Disposal: Provide ventilation to dilute and disperse small amounts of ozone (below OSHA PELs) to outside atmosphere. Follow federal, state, and local regulations.

Handling/Storage Precautions: Ensure proper personnel training and establish emergency procedures.

SECTION VIII: CONTROL MEASURES

Respiratory Protection: High Level (>10 ppm) - Self Contained Breathing Apparatus: MISH/NIOSH approved.
Low Level (0.3 - 10 ppm) - Canister Type (carbon) respirator may be used.

Eye Protection: Wear chemical safety goggles if necessary to work in high ozone (>10 ppm).

Skin Protection: Effects of ozone on skin are minimal to non-existent.

Ventilation: Provide general and local exhaust ventilation to dilute & disperse small amounts of ozone into outside atmosphere.

SECTION IX: SPECIAL PRECAUTIONS AND COMMENTS

Storage Segregation: Prevent ozone from coming into direct physical contact with strong acids or bases or with strong oxidizing/reducing agents.

Engineering Controls: Install ventilation systems capable of maintaining ozone to concentrations below the ACGIH/OSHA exposure limits (see sect. II). Install ambient ozone monitor(s) configured to shut down ozone equipment and turn high speed ventilation on.

Material Safety Data Sheet

This MSDS complies with OSHA's Hazardous Communication Standard 29 CFR 1910.1200 and OSHA form 174.

DEL Ozone
3580 Sueldo Street
San Luis Obispo, CA 93401
 Product Information 805-541-1601

NFPA 704 Designation Hazard Rating

4 = Extreme
 3 = High
 2 = Moderate
 1 = Slight
 0 = Insignificant

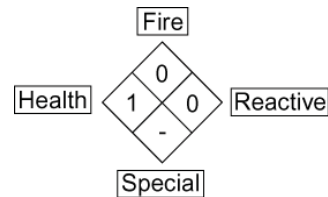

Product Name		AQUEOUS OZONE SOLUTION			
Chemical Name		DISSOLVED OZONE GAS IN WATER 0 TO 2 PPM			
Product Description		AQUEOUS SOLUTION OF OZONE DISSOLVED IN POTABLE WATER			
D.O.T. Shipping Classification		NON REGULATED			
I PHYSICAL DATA					
Boiling Point	212 F	Freezing Point	32 F		
Specific Gravity	1.0	Solubility in Water	COMPLETE		
Evaporation Rate	APPROX 1	Physical Form	LIQUID		
Appearance & Odor	COLORLESS (CLEAR) WATER WITH FRESH, ASEPTIC ODOR				
II HAZARDOUS INGREDIENTS					
MATERIAL	HAZARD	CAS #	% BY WT	ACGIH TLV	OSHA PEL
None					
III FIRE AND EXPLOSION HAZARD DATA					
Flash Point	NA	Method	NA	Auto Ign. Temp.	NA
Flammable Limits in Air	NON APPLICABLE		Lower	NA	Upper NA
Extinguishing Media	NON APPLICABLE				
Unusual Fire & Explosion Hazards	NONE				
Special Fire Fighting Procedures	NONE				

Material Safety Data Sheet Cont.Product Name **AQUEOUS OZONE SOLUTION**

IV HEALTH HAZARD DATA	
Threshold Limit Value	NOT DETERMINED
Route of Exposure	<input type="checkbox"/> Inhalation <input type="checkbox"/> Ingestion <input type="checkbox"/> Skin <input checked="" type="checkbox"/> Eye <input checked="" type="checkbox"/> Not Hazardous
Eye Contact Hazard	Exposure may cause mild eye irritation, but is not expected.
Ingestion Hazard	Not Hazardous
Inhalation Hazard	Inhalation is not likely to be a primary route of exposure but could become irritating if aerosols are exposed to individual for extended period of time.
Skin Contact Hazard	No skin irritation is expected from short term exposure.
Skin Absorption Hazard	No published data indicates this product is absorbed through the skin.
Effects of Acute Exposure	Mild skin or eye irritation.
Effects of Chronic Exposure	Repeated exposure of the skin to concentrated product should be avoided to prevent irritation and drying of the skin.
V EMERGENCY AND FIRST AID PROCEDURES	
Eye Contact	If exposure to water containing aqueous solution of ozone causes irritation to eyes, flush eyes with plenty of clean, ozone free, running water for at least 15 minutes, lifting the upper and lower lids occasionally. Remove contact lenses if worn. Seek medical attention if irritation persists.
Skin Contact	Not likely to become irritated unless repeatedly exposed to large volumes of material. If irritation develops, rinse affected area with ozone free potable water. If irritation continues seek medical advice.
Inhalation	Inhalation of mists could lead to irritation of lungs. If symptoms develop, move individual away from exposure and into fresh air. If symptoms persist, seek medical attention.
Ingestion	NA
VI REACTIVITY DATA	
Incompatibility (Materials to Avoid)	Natural rubber (may degrade, or "dry", rubber components over extended periods of exposure)
Conditions to Avoid	NONE KNOWN
Hazardous Decomposition	NONE
Stability	<input checked="" type="checkbox"/> STABLE <input type="checkbox"/> UNSTABLE Hazardous Polymerization <input type="checkbox"/> MAY OCCUR <input checked="" type="checkbox"/> WILL NOT OCCUR

Material Safety Data Sheet Cont.Product Name **AQUEOUS OZONE SOLUTION**

VII SPILL OR LEAK PROCEDURES				
Steps To Be Taken If Material Is Released Or Spilled		NONE		
Waste Disposal Method		DISPOSE OF THE SAME AS POTABLE RINSE WATER		
VIII SPECIAL PROTECTIVE INFORMATION				
Respiratory Protection (Specify Type)		NOT REQUIRED FOR NORMAL USE OF THIS PRODUCT		
Ventilation	Local Exhaust	PREFERABLE	Special	NA
	Mechanical (general)	OK	Other	NA
Protective Gloves	NOT REQUIRED			
Eye Protection	NOT REQUIRED			
Other Protective Equipment	NOT REQUIRED			
IX SPECIAL PRECAUTIONS				
Precautionary Labeling	Certified testing of DEL Ozone systems by NSF (National Sanitation Foundation) has shown that under normal conditions of use, aqueous solutions containing low levels of ozone gas dissolved in potable water do not present a safety hazard when contact to the individual is incidental. When used in a room with normal ventilation, levels of ozone gas being released into the air have been shown by NSF to be well below the periodic exposure levels established by OSHA for worker safety through the use of DEL's ozone management technology.			
Precautions To Be Taken In Handling	Aqueous solutions of ozone in potable water should not be sprayed as an aerosol (i.e. >20psi) to avoid releasing higher levels of ozone gas into the work area. The decay rate of ozone gas is a function of temperature and exposure to organic material. Certified testing has shown that when ozone gas has been properly dissolved in ambient temperature (or colder (33 – 70 °F)) potable water at a level not exceeding 2 mg/l (ppm) using DEL's ozone management technology, the rate at which ozone is released from the water as ozone gas is below the PEL established for gaseous ozone.			
Rev. Date 03/26/09				
This material safety data sheet is provided as an information resource only. It should not be taken as a warranty or representation for which the preparer assumes legal responsibility. While we believe the information contained herein is accurate and compiled from sources believed to be reliable, it is the responsibility of the user to investigate and verify its validity. The buyer assumes all responsibility of using and handling the product in accordance with applicable federal, state, and local regulations.				



3580 Sueldo Street, San Luis Obispo, CA 93401 | 800.676.1335 | o3info@delozone.com | www.delozone.com
EPA Estab. No. 071472-CA-001